



EVEKTOR–AEROTECHNIK a.s.
Letecka 1384
686 04 Kunovice
Czech Republic

tel.: +420 572 537 111
fax: +420 572 537 900
e-mail: marketing@evektor.cz
<http://www.evektor.cz>

AIRCRAFT MAINTENANCE AND INSPECTION PROCEDURES FOR **SportStar^{MAX}** LIGHT SPORT AIRCRAFT





EVEKTOR–AEROTECHNIK a.s.
Letecka 1384
686 04 Kunovice
Czech Republic

tel.: +420 572 537 111
fax: +420 572 537 900
e-mail: marketing@evektor.cz
<http://www.evektor.cz>

**AIRCRAFT MAINTENANCE
AND INSPECTION PROCEDURES
FOR
SportStar^{MAX}
LIGHT SPORT AIRCRAFT**

Serial Number: **2009 1202**

Registration: **N906SL**

Owner:

.....

.....

Document No.: SSM2008MAIPUS	Date of Issue: March 01, 2009	Revision: -	i
---------------------------------------	---	----------------	----------



The manufacturer invites suggestions and reminders concerning this manual,
and appreciates proposals for corrections.
We invite you to share your experiences with us during operation of your

SportStar ^{MAX}



1. GENERAL



1.1 Information source

Aircraft manufacturer issues information and mandatory bulletins to ensure continued airworthiness of the Light Sport Aircraft (LSA). The bulletins are provided to all known owners and dealers of the SportStar MAX aircraft.

All bulletins may be downloaded from:

<http://www.evektor.cz/at/en/index.htm#sportstar>

You can also contact us via mail, telephone, fax or e-mail mentioned on the title page.



1.2 Record of revisions

Any revisions or amendments to these instructions shall be issued in the form of bulletins with attached new pages. It is in the interests of every user to enter such revision into the table of revisions and to replace the existing page by the new one. The revised or corrected text shall be indicated by a vertical line on the page fore-edge and the page shall bear a revision number and date of its issue.

Rev. No.	Affected Section	Affected Pages	Date of Issue	Bulletin No.	Date of Approval	Date Inserted	Signature



1.3 List of Effective Pages

Sec.	Page	Date	Sec.	Page	Date	Sec.	Page	Date	Sec.	Page	Date
	i			2-27	March 01/09	3	3-1	March 01/09		4-23	March 01/09
				2-28	March 01/09		3-2	March 01/09		4-24	March 01/09
				2-29	March 01/09		3-3	March 01/09		4-25	March 01/09
1	1-1	March 01/09		2-30	March 01/09		3-4	March 01/09		4-26	March 01/09
	1-2	March 01/09		2-31	March 01/09		3-5	March 01/09		4-27	March 01/09
	1-3	March 01/09		2-32	March 01/09		3-6	March 01/09		4-28	March 01/09
	1-4	March 01/09		2-33	March 01/09		3-7	March 01/09		4-29	March 01/09
	1-5	March 01/09		2-34	March 01/09		3-8	March 01/09		4-30	March 01/09
	1-6	March 01/09		2-35	March 01/09		3-9	March 01/09		4-31	March 01/09
	1-7	March 01/09		2-36	March 01/09		3-10	March 01/09		4-32	March 01/09
	1-8	March 01/09		2-37	March 01/09		3-11	March 01/09		4-33	March 01/09
				2-38	March 01/09		3-12	March 01/09		4-34	March 01/09
				2-39	March 01/09		3-13	March 01/09		4-35	March 01/09
				2-40	March 01/09		3-14	March 01/09		4-36	March 01/09
2	2-1	March 01/09		2-41	March 01/09		3-15	March 01/09		4-37	March 01/09
	2-2	March 01/09		2-42	March 01/09		3-16	March 01/09		4-38	March 01/09
	2-3	March 01/09		2-43	March 01/09		3-17	March 01/09		4-39	March 01/09
	2-4	March 01/09		2-44	March 01/09		3-18	March 01/09		4-40	March 01/09
	2-5	March 01/09		2-45	March 01/09		3-19	March 01/09			
	2-6	March 01/09					3-20	March 01/09			
	2-7	March 01/09					3-21	March 01/09			
	2-8	March 01/09					3-22	March 01/09	5	5-1	March 01/09
	2-9	March 01/09								5-2	March 01/09
	2-10	March 01/09								5-3	March 01/09
	2-11	March 01/09								5-4	March 01/09
	2-12	March 01/09				4	4-1	March 01/09		5-5	March 01/09
	2-13	March 01/09					4-2	March 01/09		5-6	March 01/09
	2-14	March 01/09					4-3	March 01/09		5-7	March 01/09
	2-15	March 01/09					4-4	March 01/09		5-8	March 01/09
	2-16	March 01/09					4-5	March 01/09		5-9	March 01/09
	2-17	March 01/09					4-6	March 01/09		5-10	March 01/09
	2-18	March 01/09					4-7	March 01/09		5-11	March 01/09
	2-19	March 01/09					4-8	March 01/09		5-12	March 01/09
	2-20	March 01/09					4-9	March 01/09		5-13	March 01/09
	2-21	March 01/09					4-10	March 01/09		5-14	March 01/09
	2-22	March 01/09					4-11	March 01/09		5-15	March 01/09
	2-23	March 01/09					4-12	March 01/09		5-16	March 01/09
	2-24	March 01/09					4-13	March 01/09			
	2-25	March 01/09					4-14	March 01/09	6	6-1	March 01/09
	2-26	March 01/09					4-15	March 01/09		6-2	March 01/09
							4-16	March 01/09			
							4-17	March 01/09			
							4-18	March 01/09			
							4-19	March 01/09			
							4-20	March 01/09			
							4-21	March 01/09			
							4-22	March 01/09			



1.4 Contents

1. GENERAL	1-1
1.1 INFORMATION SOURCE.....	1-2
1.2 RECORD OF REVISIONS.....	1-3
1.3 LIST OF EFFECTIVE PAGES.....	1-4
1.4 CONTENTS.....	1-5
2. TECHNICAL DESCRIPTION	2-1
2.1 BASIC AND GENERAL INFORMATION.....	2-2
2.1.1 <i>Designation</i>	2-2
2.2 BASIC TECHNICAL DATA.....	2-3
2.2.1 <i>Airplane views</i>	2-3
2.2.2 <i>Three-view drawing</i>	2-4
2.2.3 <i>Basic dimensions</i>	2-5
2.2.4 <i>Weight</i>	2-6
2.2.5 <i>Center of gravity</i>	2-6
2.2.6 <i>Operating limitations</i>	2-6
2.3 TECHNICAL DESCRIPTION OF THE AIRPLANE.....	2-7
2.3.1 <i>General</i>	2-7
2.3.2 <i>Fuselage</i>	2-7
2.3.3 <i>Wing</i>	2-7
2.3.4 <i>Horizontal tail unit</i>	2-7
2.3.5 <i>Vertical tail unit</i>	2-8
2.3.6 <i>Landing gear</i>	2-9
2.3.7 <i>Cockpit</i>	2-16
2.3.8 <i>Equipment</i>	2-19
2.3.9 <i>Instrument panel</i>	2-19
2.3.10 <i>Avionics</i>	2-19
2.3.11 <i>Additional equipment</i>	2-19
2.3.12 <i>Control system</i>	2-20
2.3.13 <i>Powerplant</i>	2-30
2.3.14 <i>Fuel system</i>	2-37
2.3.15 <i>Engine lubrication system scheme</i>	2-40
2.3.16 <i>Cooling system description</i>	2-40
2.3.17 <i>Heating</i>	2-41
2.3.18 <i>Ventilation</i>	2-42
2.3.19 <i>Wiring</i>	2-43
2.3.20 <i>Pitot-static system</i>	2-44
2.3.21 <i>Placards</i>	2-45
3. OPERATION	3-1
3.1 OPERATION OUTLINES.....	3-2
3.2 AIRPLANE ASSEMBLY.....	3-3
3.2.1 <i>Wing</i>	3-3
3.2.2 <i>Horizontal tail unit</i>	3-5
3.2.3 <i>Vertical tail unit</i>	3-6
3.2.4 <i>Landing gear</i>	3-7
3.2.5 <i>Cockpit canopy</i>	3-10
3.2.6 <i>Installation and reinstallation of instruments</i>	3-11
3.3 LEVELING.....	3-12
3.4 MEASUREMENT OF CONTROL SURFACES DEFLECTIONS.....	3-13
3.4.1 <i>Required deflections</i>	3-13
3.4.2 <i>Aileron deflection measurement</i>	3-14
3.4.3 <i>Flap deflection measurement</i>	3-14
3.4.4 <i>Elevator deflections measurement</i>	3-15
3.4.5 <i>Rudder deflection measurement</i>	3-15
3.4.6 <i>Trim tab deflections measurement</i>	3-16



3.5	PERMISSIBLE TOLERANCES.....	3-17
3.6	WEIGHING THE AIRPLANE AND C.G. CALCULATION.....	3-18
3.6.1	<i>Empty weight determination.....</i>	3-18
3.6.2	<i>Operating C.G. Range calculation</i>	3-19
3.7	GROUND HANDLING.....	3-20
3.7.1	<i>Towing the airplane.....</i>	3-20
3.7.2	<i>Parking the airplane</i>	3-20
3.7.3	<i>Tieing-Down.....</i>	3-20
3.7.4	<i>Jacking the airplane</i>	3-21
3.8	ROAD TRANSPORT	3-21
4.	MAINTENANCE	4-1
4.1	OVERALL MAINTENANCE SURVEY	4-2
4.1.1	<i>Terminology</i>	4-2
4.1.2	<i>Qualification requirements</i>	4-5
4.2	PRE-FLIGHT INSPECTION	4-7
4.3	POST-FLIGHT INSPECTION	4-8
4.4	PERIODICAL INSPECTIONS	4-8
4.4.1	<i>Periodical inspection intervals.....</i>	4-8
4.4.2	<i>Periodical inspection actions.....</i>	4-8
4.4.3	<i>Periodical Inspections Checklists.....</i>	4-9
4.5	FLUIDS.....	4-16
4.5.1	<i>Engine oil</i>	4-17
4.5.2	<i>Coolant.....</i>	4-20
4.5.3	<i>Brake fluid</i>	4-21
4.5.4	<i>Fuel</i>	4-23
4.6	LUBRICATION.....	4-26
4.6.1	<i>Lubrication fundamentals.....</i>	4-26
4.6.2	<i>Recommended lubricants</i>	4-26
4.7	MECHANISM ADJUSTMENTS	4-28
4.7.1	<i>Torque moments.....</i>	4-28
4.8	NECESSARY MAINTENANCE TOOLS.....	4-29
4.9	ACCESS HOLES.....	4-29
4.10	BRAKE SYSTEM EFFICIENCY ADJUSTMENT	4-30
4.10.1	<i>Brake pad replacement</i>	4-30
4.10.2	<i>Bleeding.....</i>	4-31
4.11	CONTROL SURFACES DEFLECTION SETTING	4-32
4.11.1	<i>Aileron deflection adjustment</i>	4-32
4.11.2	<i>Flap deflection adjustment.....</i>	4-32
4.11.3	<i>Elevator deflection adjustment</i>	4-33
4.11.4	<i>Rudder deflection adjustment.....</i>	4-33
4.11.5	<i>Trim tab adjustment.....</i>	4-33
4.12	STEERABLE NOSEWHEEL LANDING GEAR ADJUSTMENT.....	4-34
4.12.1	<i>Rubber shock absorber replacement</i>	4-34
4.13	ENGINE IDLE ADJUSTMENT	4-35
4.14	TIRE INFLATION PRESSURE	4-36
4.15	CLEANING AND CARE	4-37
4.15.1	<i>Airplane care outlines.....</i>	4-37
4.15.2	<i>External surfaces cleaning</i>	4-37
4.15.3	<i>Interior cleaning.....</i>	4-37
4.15.4	<i>Cockpit canopy cleaning</i>	4-37
4.15.5	<i>Engine maintenance.....</i>	4-38
4.15.6	<i>Propeller maintenance.....</i>	4-38
4.15.7	<i>Winter operation</i>	4-39
5.	REPAIRS.....	5-1
5.1	REPAIR GUIDELINES.....	5-2
5.1.1	<i>Repair clasification.....</i>	5-2
5.1.2	<i>Repair guidelines</i>	5-2
5.2	DAMAGE CLASSIFICATION.....	5-2

1-6	Document No.: SSM2008MAIPUS	Date of Issue: March 01, 2009	Revision: -
------------	--	--	-----------------------



5.3 MATERIALS USED 5-3

5.3.1 *List of skin sheets* 5-3

5.4 SKIN REPAIR..... 5-4

5.4.1 *Riveting*..... 5-5

5.5 FIBERGLASS PARTS REPAIRS 5-6

5.5.1 *Damage classification*..... 5-6

5.5.2 *General*..... 5-6

5.5.3 *Parts of external appearance*..... 5-6

5.5.4 *Structural parts* 5-8

5.6 PAINT REPAIRS 5-9

5.6.1 *Safety rules*..... 5-9

5.6.2 *Recommendation for paint repairs*..... 5-9

5.6.3 *Small damage*..... 5-12

5.7 AIRPLANE ASSEMBLY AND LEVELING AFTER A REPAIR 5-14

5.8 FIRST FLIGHT AFTER A REPAIR..... 5-15

5.9 SPARE PARTS ORDER 5-15

5.10 RECOMMENDED READING 5-15

6. APPENDICES 6-1

6.1 LIST OF APPENDICES 6-2



Intentionally left blank



2. TECHNICAL DESCRIPTION



2.1 Basic and general information

The **SportStar MAX** is a single engine, metal-composite, low-wing monoplane of semimonocoque construction with two side-by side seats. The aircraft is equipped with fixed, tricycle landing gear. The standard power plant consists of the four-cylinder, 4 stroke ROTAX 912 ULS (100 hp) engine and on-ground adjustable, 3 bladed, composite, WOODCOMP KLASSIC 170/3/R prop. For concrete engine / propeller type see Supplement No. 1 – Description of actual airplane.

2.1.1 Designation

SportStar MAX is an aircraft especially intended for recreational and cross-country flying with a limitation to non-aerobatic operation.



2.2 Basic technical data

2.2.1 Airplane views



Note: US version of the SportStar MAX is fitted with a row of vortex generators along the whole wing span. These are not shown on the pictures above.



2.2.2 *Three-view drawing*

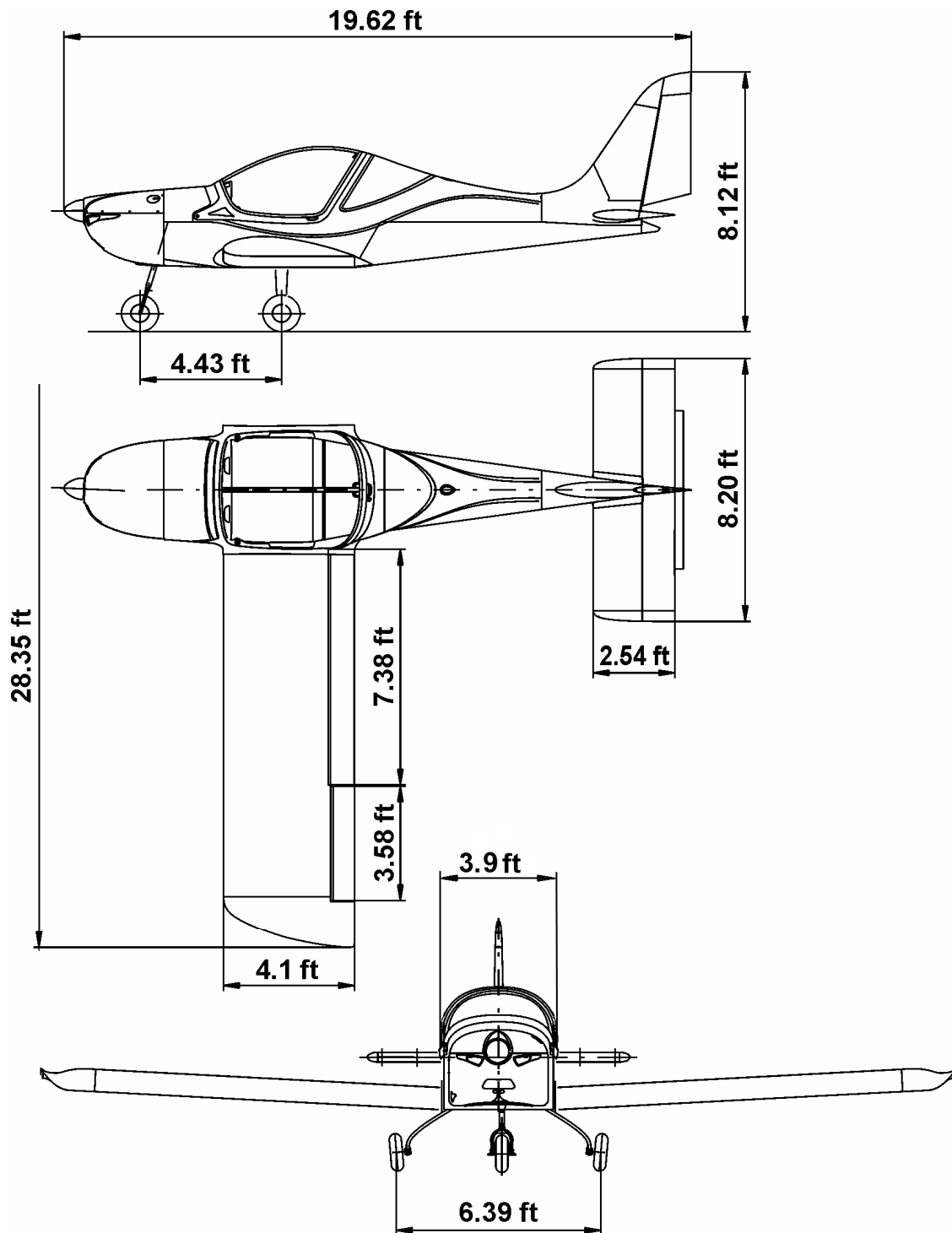

2-4	Document No.: SSM2008MAIPUS	Date of Issue: March 01, 2009	Revision: -
-----	--------------------------------	----------------------------------	----------------



2.2.3 Basic dimensions

Wing

span.....	28.37 ft	8.646 m
area	112.7 sq.ft	10.47 sq.m
MAC	4.1 ft	1.25 m
Loading.....	11.71 lbs/sq.ft	57.30 kg/sq.m

Aileron

area	2.62 sq.ft	0.25 sq.m
------------	------------	-----------

Flap

area	5.60 sq.ft	0.52 sq.m
------------	------------	-----------

Fuselage

length.....	19.62 ft	5.98 m
width	3.55 ft	1.082 m
height.....	7.66 ft	2.335 m
cockpit canopy max. width	3.9 ft	1.180 m

HTU

span.....	8.20 ft	2.5 m
HTU area.....	20.88 sq.ft	1.94 sq.m
elevator area	8.4 sq.ft	0.8 sq.m

VTU

height.....	4.21 ft	1.28 m
VTU area	10.99 sq.ft	1.02 sq.m
rudder area.....	4.67 sq.ft	0.43 sq.m

Landing gear

wheel track	6.39 ft	1.95 m
wheel base	4.43 ft	1.350 m
main wheel diameter	15 in	380 mm
nosewheel diameter	15 in	380 mm



2.2.4 Weight

Empty weight (standard equipment).....	740 lbs ± 2%	335 kg ± 2%
Maximum Take-off weight	1320 lbs	600 kg
Maximum Landing weight	1320 lbs	600 kg
Maximum weight in Baggage Compartment	55 lbs	25 kg

NOTE

Actual empty weight is stated on the placard "LOAD LIMITS," located on the cockpit canopy.

2.2.5 Center of gravity

Empty weight CG (standard equipment)	20 ± 2 % MAC
Operating CG	20 - 34 % MAC

(MAC...Mean Aerodynamic Chord)

2.2.6 Operating limitations

Refer to the AIRCRAFT OPERATING INSTRUCTIONS (AOI), Section 2 for more details about the following operating limits:

- Airspeed limits
- Weight limits
- CG Range limits
- Approved maneuvers

Additional rules are of a more common character and result from generally valid flight regulations. It is in every user's interest to be familiar with these regulations, rules and restrictions.



2.3 Technical description of the airplane

2.3.1 General

The **SportStar MAX** airframe is of semi-monocoque construction formed with metal reinforcements, bulkheads and duralumin cover. Pop-rivets and a sealant are used for joints. The canopy, fuselage aft section top, as well as some other non-supporting parts (cowlings, wing tips, etc.) are made from fiberglass.

2.3.2 Fuselage

The fuselage is a combination of semimonocoque structure consisting of reinforcements and duralumin skin, with a composite fuselage aft section top and composite canopy. Fuselage section is rectangular in the lower part and elliptic in the upper part. The fin is an integral part of fuselage. The cockpit for two-member crew is located in the middle part of the fuselage that is accessible after uncovering the single-piece organic glass composite canopy. The engine compartment in the front part of the fuselage is separated from the cockpit by the steel firewall to which the engine bed is attached.

2.3.3 Wing

The wing is of rectangular shape, single-spar structure with the auxiliary spar with suspended ailerons and split wing flaps. Riveting is used for connecting individual structural elements. Fiberglass wing tips are riveted on the wing ends. There is an integral fuel tank inside each wing half, in the section between the main and auxiliary spar at the wing root.

2.3.3.1 Ailerons

The ailerons are of rectangular shape on each half of the wing and are attached to the wing with hinges. An aileron is formed with the ribs and cover, which forms a hollow section.

2.3.3.2 Trim tab

Left aileron is optionally equipped with electrically controlled trim tab.

2.3.3.3 Flaps

Two-third's of each half of the wing is fitted with a flap. The flaps are of rectangular shape and are formed with the ribs and cover, which forms a hollow section. The flap is attached to the wing with a hinge.

2.3.4 Horizontal tail unit

The VTU of conventional type consists of the stabilizer and elevator with the trim tab. Single-spar structure of HTU consists of duralumin ribs, spar and skin. Top view of HTU is of rectangular shape. The width of 8.20 ft (2.5 m) enables transport without dismantling.

2.3.4.1 Stabilizer

The stabilizer is rectangular in shape and formed with a duralumin cover and ribs. The stabilizer is attached to the fuselage with two pins at the leading edge and secured with two screws at the stabilizer trailing edge.

2.3.4.2 Elevator

The elevator is rectangular in shape and formed with a duralumin cover and ribs. The elevator is attached to the stabilizer with a hinge. There is also a hinged trim tab at the elevator trailing edge.

2.3.4.3 Trim tab

Elevator is equipped with the trim tab of rectangular shape. The tab is formed with duralumin plate. The span of the trim tab is approx. 2/3 of the elevator spanwise.



2.3.5 Vertical tail unit

The trapezoidal VTU consists of the fin and rudder. The rudder is attached on the fin by two hinges. The frame of the VTU is composed of a metal sheet spar and a duralumin cover.

2.3.5.1 Fin

The fin is an integral part of the fuselage rear section and is formed with a duralumin spar and cover. The fin tip is formed with a fiberglass cover, where the anticollision beacon can be installed. The fillet between the fin and rear upper fuselage part is formed with a fiberglass fillet cover.

2.3.5.2 Rudder

The rudder is of trapezoidal shape and formed with a duralumin spar and cover and attached by two hinges at the fin. The rudder upper tip is formed with a fiberglass cover.



2.3.6 Landing gear

2.3.6.1 General description

The aircraft is equipped with fixed nosewheel landing gear. The nosewheel is steerable.

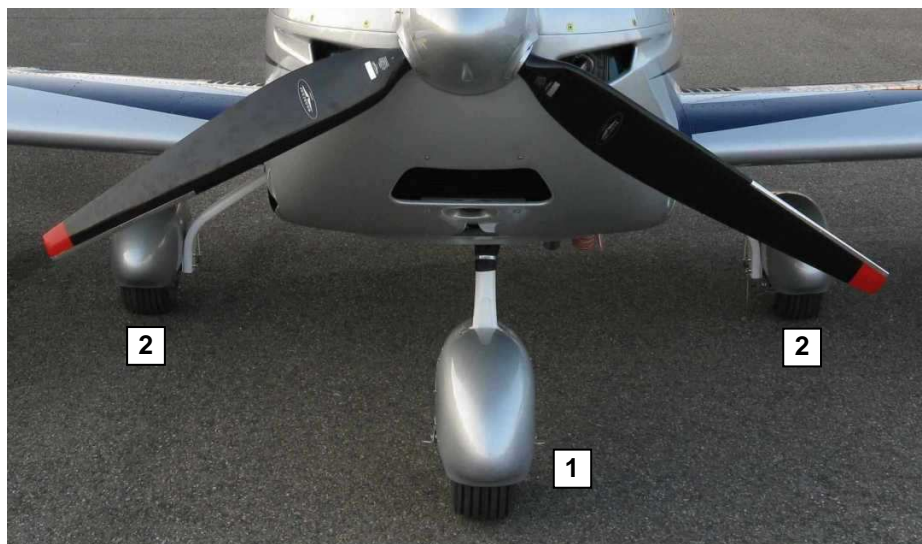

Fig. Landing gear
1 - Steerable nosewheel
2 - Main landing gear

2.3.6.2 Main landing gear

2.3.6.2.1 Description

The main landing gear consists of the left and right landing gear legs. The legs are formed from fiberglass springs and are fixed by means of screws in the fuselage casing under the seats. Wheel axis is screwed at the lower part of the main landing gear legs. The main wheels on both legs are equipped with hydraulic disc brakes controlled with toe brake pedals mounted on the rudder pedals. The wheels can be covered with the fiberglass fairings (wheel pants) or mudguards.

2.3.6.3 Nosewheel landing gear

2.3.6.3.1 Description

Steerable nose landing gear consists of front landing gear leg, rubber rope suspension unit and suspension stop. The nose leg is made of a bent steel tube, attached to the firewall by two bearings. The axle, with wheel attached, is connected to the welded bushing in the bottom part of the leg. Two rods are used for the leg steering by the control pedals.



2.3.6.3.2 Main landing gear layout

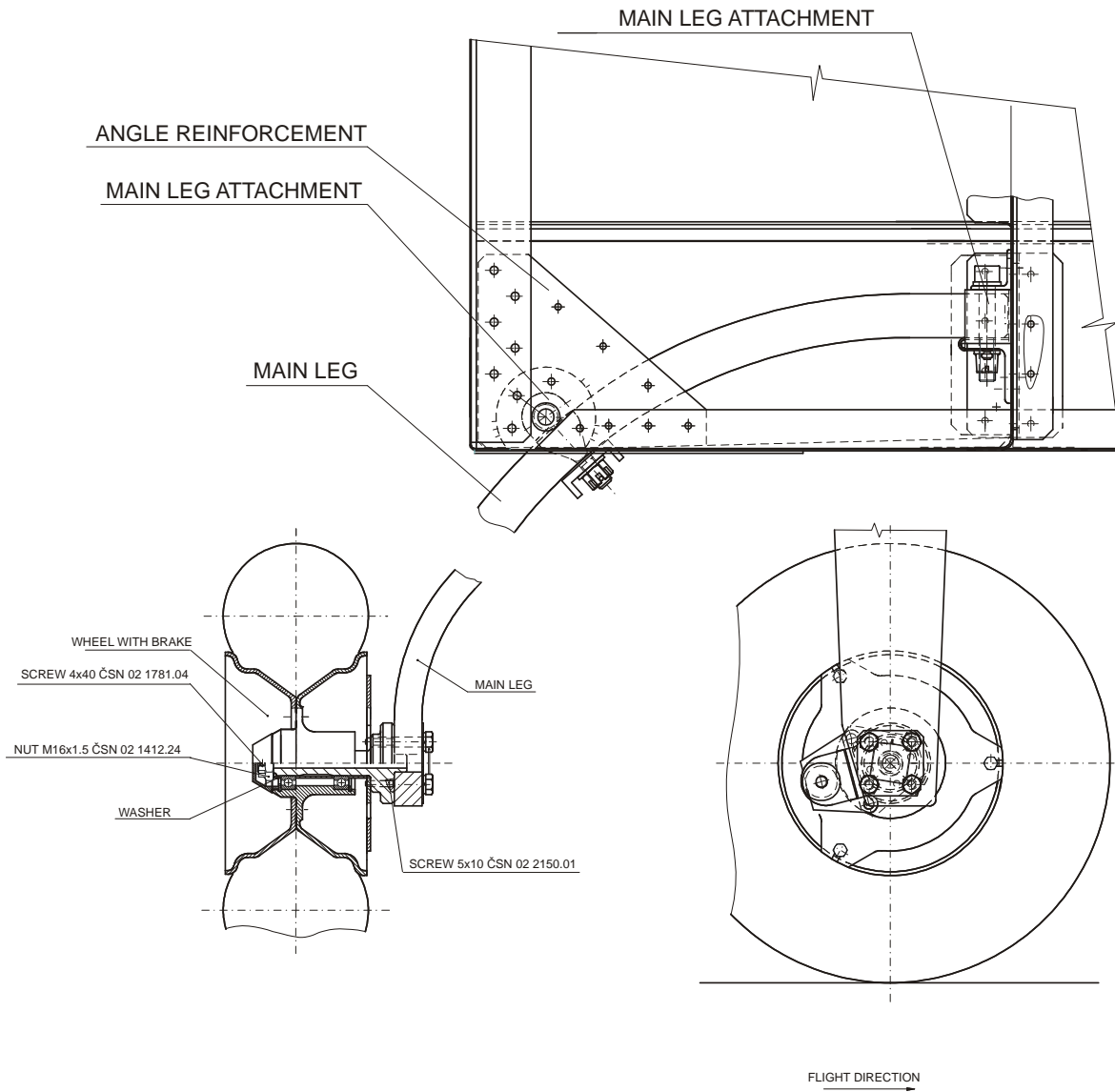
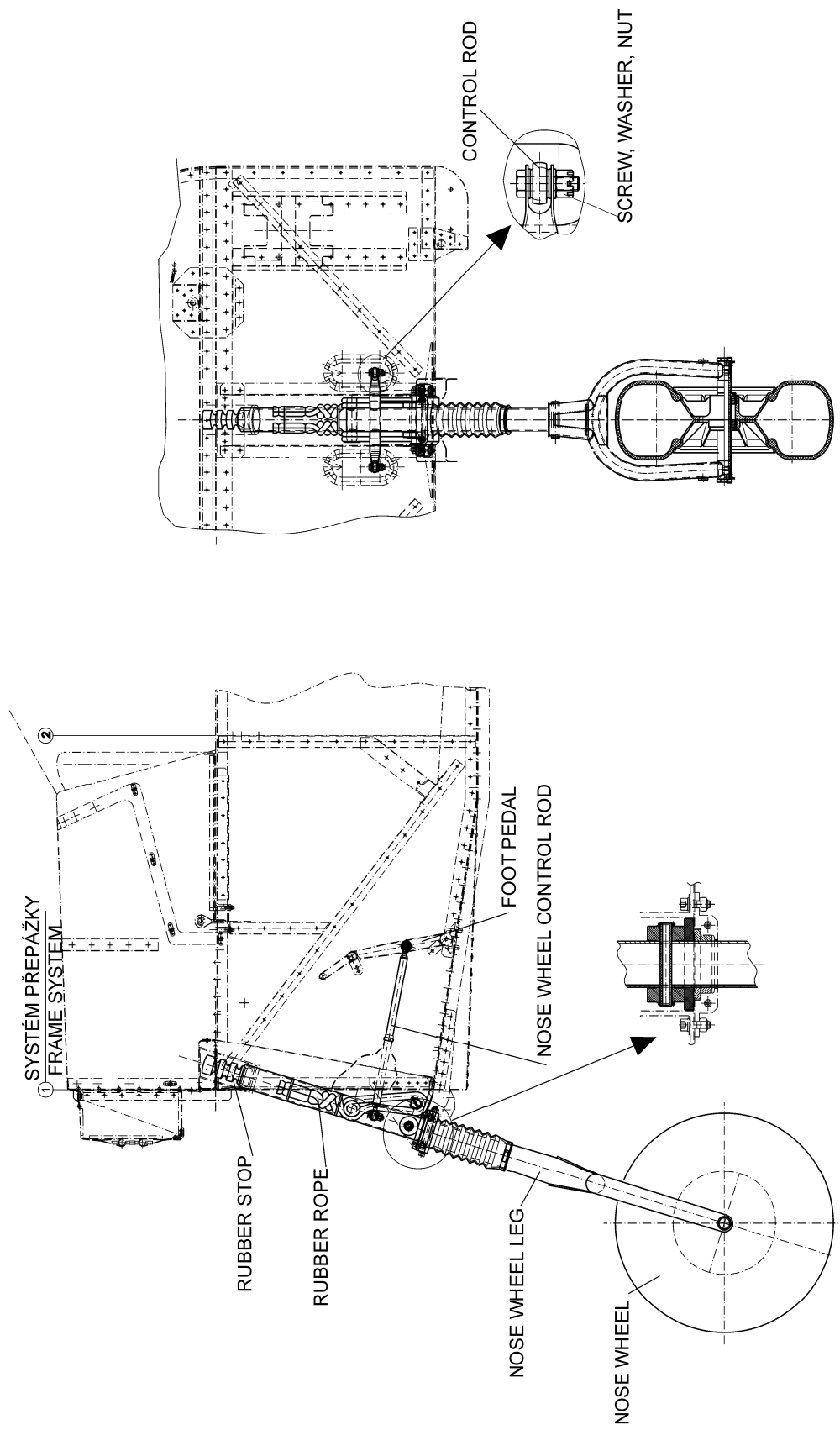

Fig. Main leg attachment into fuselage



2.3.6.3.3 Steerable nosewheel landing gear layout





2.3.6.4 Auxiliary tail skid

2.3.6.4.1 Description

The auxiliary tail skid is attached at the lower rear part of the fuselage and protects the aircraft from inadvertent damage during tail-down landing conditions. The tail skid is formed from duralumin sheet.



Fig. Auxiliary tail skid



2.3.6.5 Wheel brakes

2.3.6.5.1 Description

Both wheels on the main landing gear are equipped with hydraulic disc brakes. The brake system consists of the brake pedals (pilot standard, co-pilot as an option), hydraulic brake master cylinders, plastic hoses, brake caliper with the hydraulic brake cylinder, brake pads and the brake disc which is bolted onto the inner part of the rim.

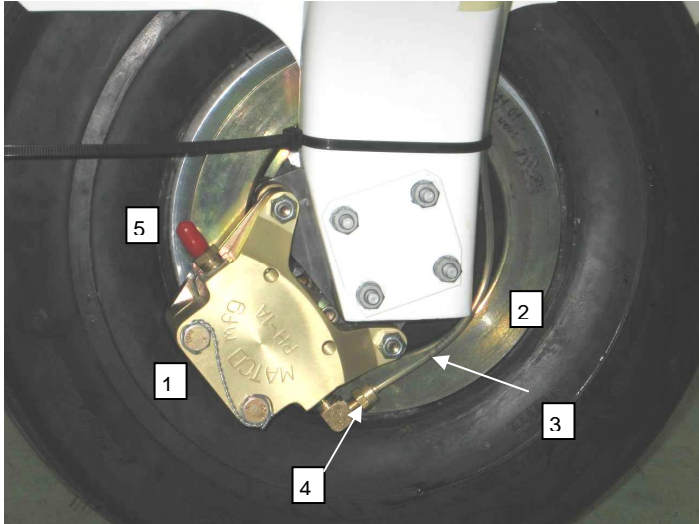

Fig. The MATCO brake on the left wheel (MATCO)

- 1- brake caliper with the hydraulic cylinder
- 2 - brake disc
- 3 - brake fluid hose
- 4 - terminal
- 5 - air bleed screw

2.3.6.5.2 Brake control

The brakes on both wheels are controlled independently by toe brake pedals mounted on the pilot's and the co-pilot's rudder pedals.

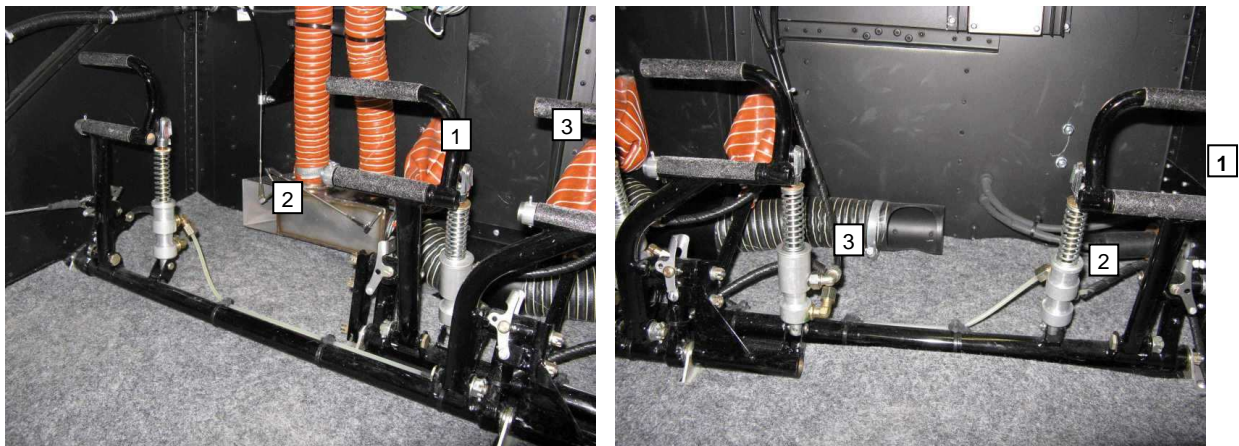
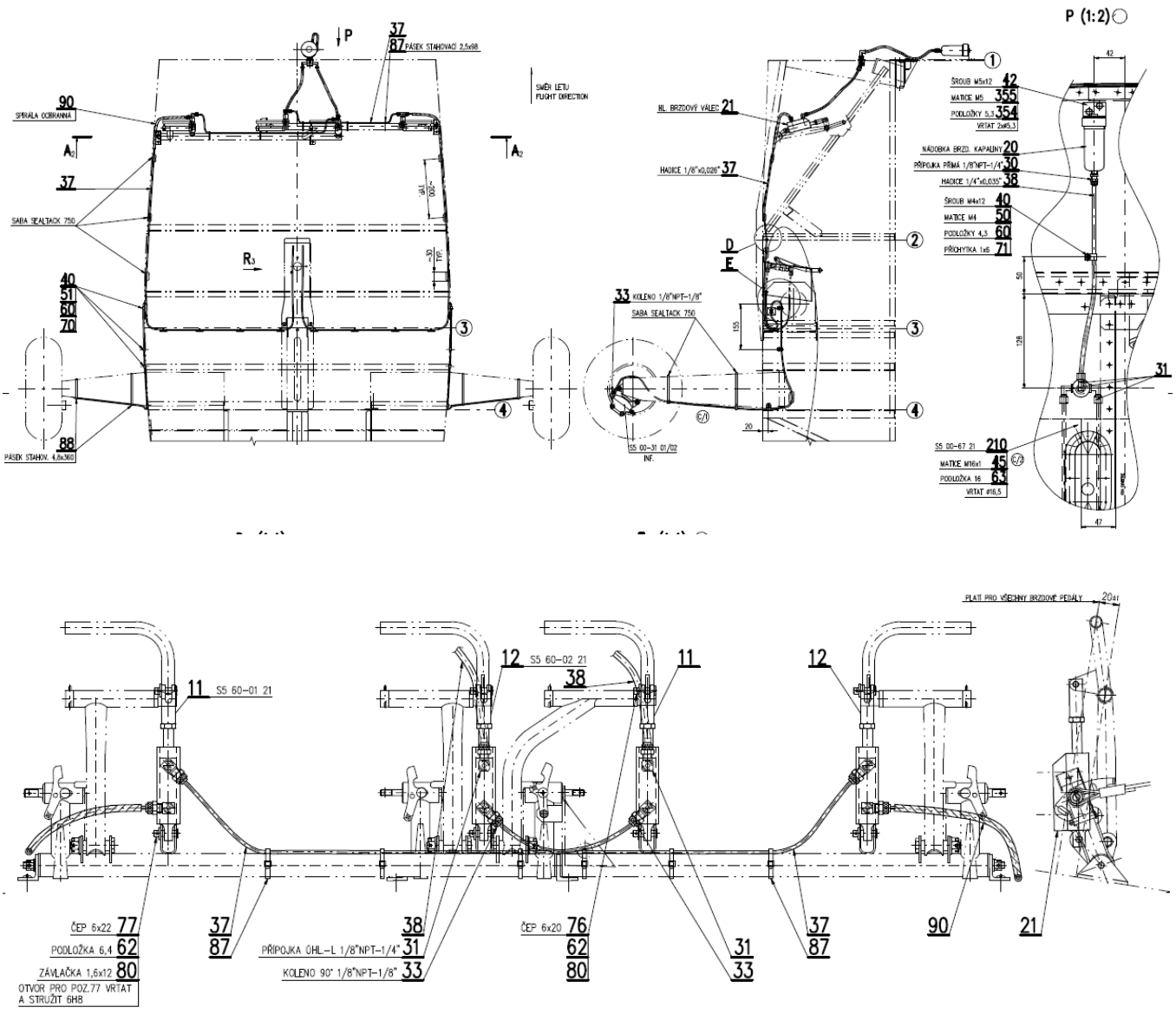

Fig. The brake control with toe brake pedals

- 1 – ruder pedals, 2 – brake cylinder, 3 – nose wheel steering rod



2.3.6.5.3 Brake system layout





2.3.6.6 Wheels

2.3.6.6.1 Description

All the wheels consist of a two-part casting rim with a tire and tube. The main wheels are on an axle attached to the main gear leg, fastened by the nuts.

2.3.6.6.2 Main undercarriage wheel layout

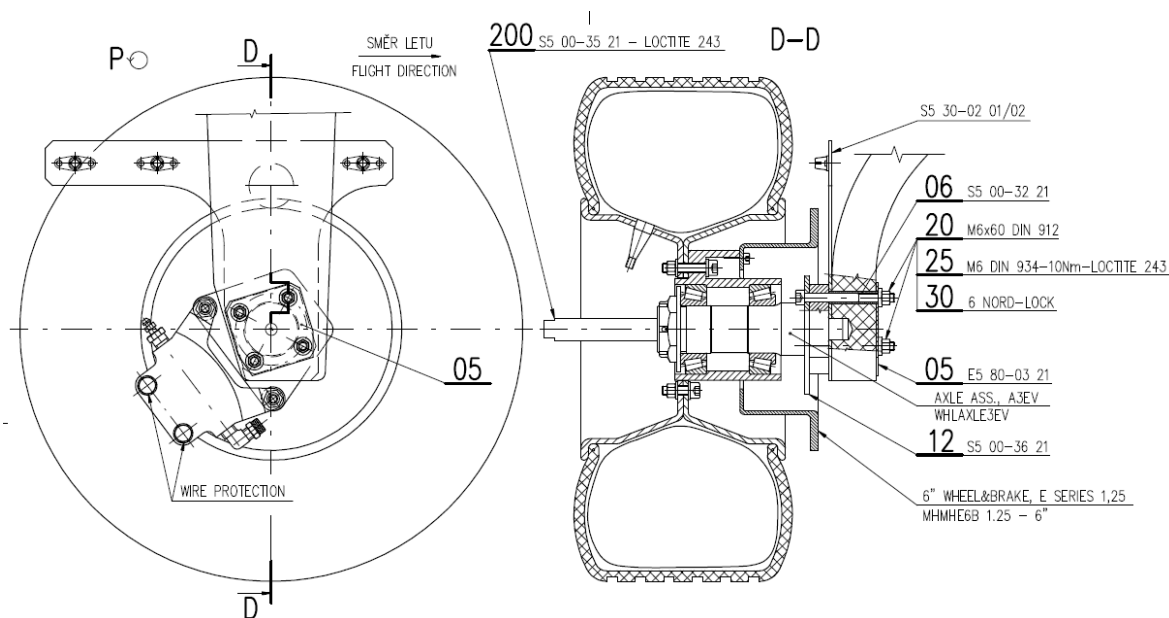

2.3.6.6.3 Nosewheel layout

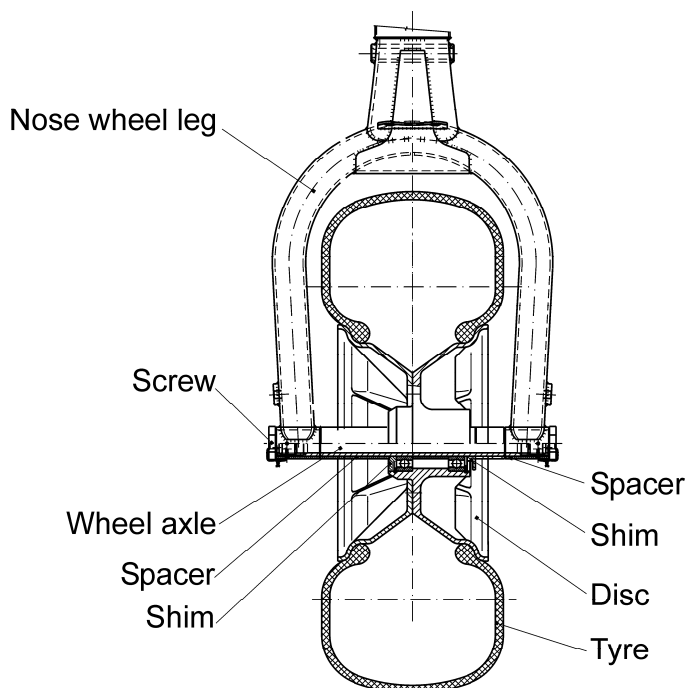



2.3.6.7 Tires

All wheels.....CHENG SHIN 15 x 6.00 – 6 (standard) or optional:
GOOD YEAR 15 x 6.00 – 6
SAVA 14x4

2.3.7 Cockpit

2.3.7.1 Description

The comfortable cockpit has a side-by-side, dual control arrangement, which provides the crew with an excellent view and comfort. It protects the crew from adverse weather conditions, and allows easy access to the controls and instruments.

The instrument panel is located in front of the crew. The flap control lever, elevator trim tab lever and optional towing mechanism release lever are located on the quadrant between seats. Optionally, the trim may be electric, with the control buttons on top of the control stick grip. A baggage compartment is situated behind the seats.

The cockpit floor is covered with a removable carpet and the seats are also covered with a thin upholstery. The interior cockpit sides are covered with padded panels containing pockets. The actual cockpit controls and instrument arrangement is described later.

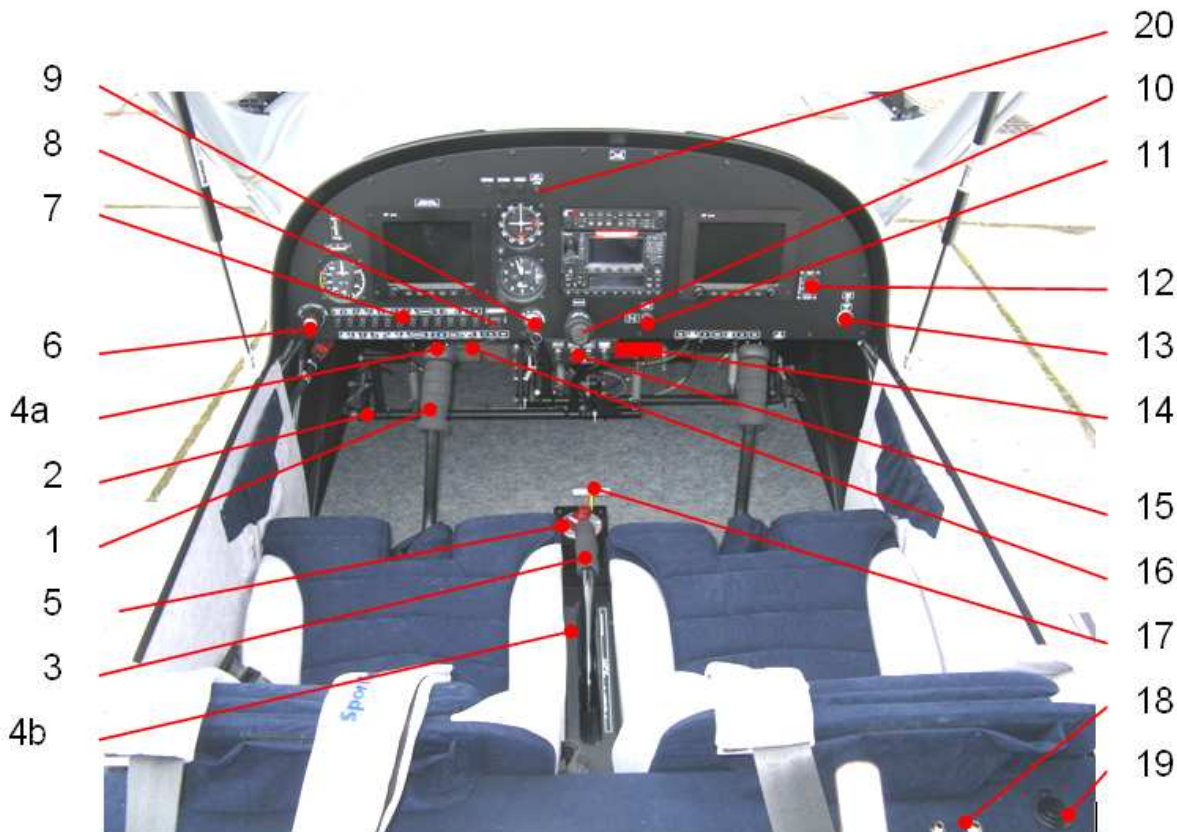

Fig.: Cockpit of the SportStar MAX



2.3.7.2 Cockpit controls

A sample of the cockpit control arrangement is shown in the following figure. A detailed instrument panel is shown in par. 2.3.9.



1.	Control stick	2.	Rudder pedals
3.	Flap control lever	4.	4a Electric trim (option) 4b Elevator trim control lever
5.	Fuel tank selector	6.	Static pressure selector (option)
7.	Switches (depending on equipment)	8.	Master switch
9.	Switch box	10.	Throttle lever
11.	Choke lever	12.	ELT switch
13.	12V socket	14.	Emergency parachute system lever (option)
15.	Knobs from the left: • Cold air • Hot air • Canopy defog • Carburetter pre-heating	16.	Pop-up breakres (depending on equipment)
17.	Parking brake lever (option)	18.	Headset sockets
19.	Additional 12V socket (option)	20.	Dimmer (option)



2.3.7.3 Cockpit canopy

The fiberglass bubble canopy consists of two parts. The front perspex portion can be tilted forward and is attached to a composite frame. The fixed rear portion is made of perspex. The canopy is attached to the nose section of the fuselage by two pins which make it possible for the canopy to be tilted forward. For easier manipulation, the weight of the canopy is counterbalanced by two gas struts which allow effortless opening. The canopy is equipped with a lock on the upper rear section of the frame.

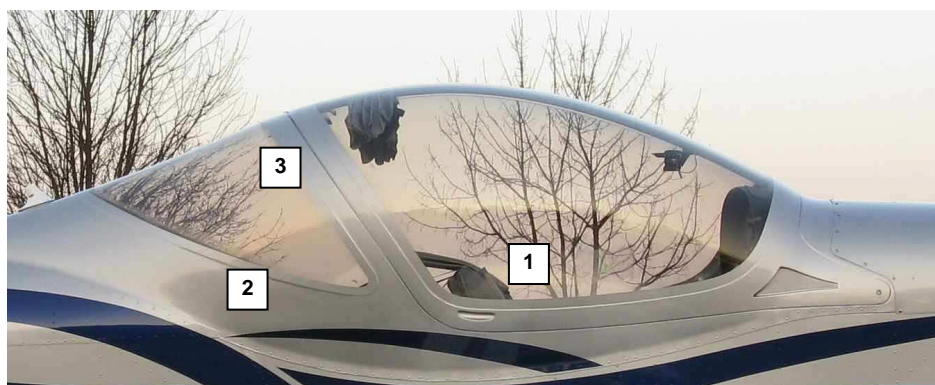

Fig. Two-parts cockpit canopy
1- front tilted canopy, 2 - rear fixed canopy, 3 - canopy lock,

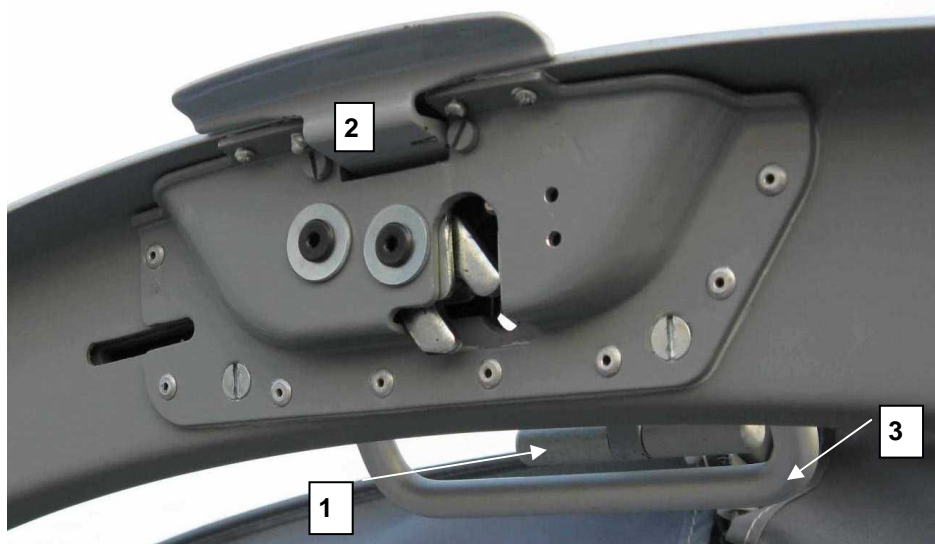

Fig. Cockpit canopy lock
1- inside lever
2 - outside lever
3 – grab handle



Fig. Cockpit canopy lock
Cockpit is unlocked, when a latch is visible under the glass, otherwise it is locked.
1 - latch



2.3.8 Equipment

2.3.8.1 Seats and safety harness

The plane has two side-by-side seats which are fixed and covered with upholstery, each equipped with four-point seatbelts. Adjustable rudder pedals are optional. The waist belt is attached alongside the seat and shoulder belts behind the seats.

2.3.8.2 Baggage compartment

The baggage compartment is situated behind the seats. It is equipped with the nets to prevent baggage movement.

Maximum baggage weight is stated on a placard located near the compartment.

There are pockets on both cockpit interior sides for small objects (maps, pencils, keys etc.).



Fig. Baggage compartment
1 - safety seat belts, 2 - baggage compartment

WARNING

A SPACE BEHIND THE BAGGAGE COMPARTMENT, WHERE THE ELT IS LOCATED, IS NOT INTENDED AS AN ADDITIONAL BAGGAGE COMPARTMENT. DO NOT PLACE THERE ANY HEAVY OBJECTS! AIRPLANE REAR C.G. LIMIT MAY BE EXCEEDED IN SUCH CASE!

2.3.9 Instrument panel

See Supplement No. 1 to this Airplane Maintenance and Inspection Procedures.

2.3.10 Avionics

See Supplement No. 1 to this Airplane Maintenance and Inspection Procedures.

2.3.11 Additional equipment

See Supplement No. 1 to this Airplane Maintenance and Inspection Procedures.



2.3.12 Control system

2.3.12.1 Longitudinal control system description

The airplane is equipped with a classic dual control system. The elevator is controlled by a control stick, with connecting rods and arms. A control stick push/pull movement is transmitted, by a rod inside the quadrant between the seats to the elevator through a two-armed lever located underneath the baggage compartment floor cover. The angular displacement of the two-armed lever is transferred by a longitudinal motion of two rods, connected with a single arm lever, inside the middle rear part of the fuselage. The rear rod is connected to the elevator single-arm lever.

A control stick motion is limited by two stops. Both control sticks have a common "push-down" stop on the center-section and each control stick has a "pull-up" stop formed with a reinforcement riveted on the front edge of each seat. The rods have adjustable ends and swivel bearings to adjust the elevator deflections.

2.3.12.2 Lateral control system description

The ailerons are controlled by control sticks, connecting rods and arms. A control stick lateral motion is transferred by a short rod in the cockpit to a longitudinal movement of a longer rod in the wing. This in turn transfers to the angular displacement of a two-armed lever attached to the wing main spar. The two-armed lever angular movement is transferred to the ailerons by short rods. The rods have adjustable ends to adjust the aileron deflections. The control stick has a termination stop.

Electric aileron trim tab control can be installed optionally. Control switches are located on the control stick, trim tab position indicator is located on the instrument panel.

CAUTION

To adjust an aileron deflection, never use the adjustable end of the short rod which is accessible when wing fillet (covering the space between the wing and fuselage) is removed. See Figure in 2.3.12.8.

2.3.12.3 Directional control system description

The rudder control system is dual. The rudder is controlled by cables attached at the rudder pedals and guided alongside the fuselage sides to the rudder. The rudder control cable is equipped with adjusting stops located in the cockpit (see figure on page 2-24). The rudder pedals are attached to the cockpit floor. There are toe brake pedals on the pilot's and copilot's rudder pedals to operate the main wheel brakes. The cables are connected to the hinges in the lower part of the rudder leading edge. The cables are prestressed by means of nose wheel control rods. The rudder control is connected to the nosewheel landing gear to control the nosewheel by the adjustable rods.



2.3.12.4 Flap control system description

The wing flaps are controlled by a control lever in a changing gate. The lever push/pull movement is transferred to a longitudinal movement of a rod guided inside the quadrant between the seats. Then to an angular displacement of a two-armed lever welded onto a tube connecting left and right flap. The flap control lever is located in the quadrant between the seats. When a lock button located on the upper end of the lever is pressed, the lock pin is pulled out of the groove in the changing gate. The flaps can then be extended to a position for takeoff or landing. The flap position is locked when the lock button is released.

2.3.12.5 Trim tab control system description

The elevator trim tab is controlled by the control lever located in the quadrant between the seats. The trim tab control lever movement is transmitted to the trim tab displacement by bowden cables. Maximum trim tab deflections can be adjusted by means of adjusting screws on the upper or lower tab surface.

Electric elevator trim tab control can be installed optionally. Control switches are located on the control stick, trim tab position indicator is located on the instrument panel.

2.3.12.6 Nosewheel control system description

The aircraft is equipped with steerable nosewheel landing gear. In this case the wheel control system is connected to the rudder pedals. The nosewheel control system consists of the rods, connecting pedals and a two-armed lever welded to the nose landing gear leg.



2.3.12.7 Longitudinal control system layout

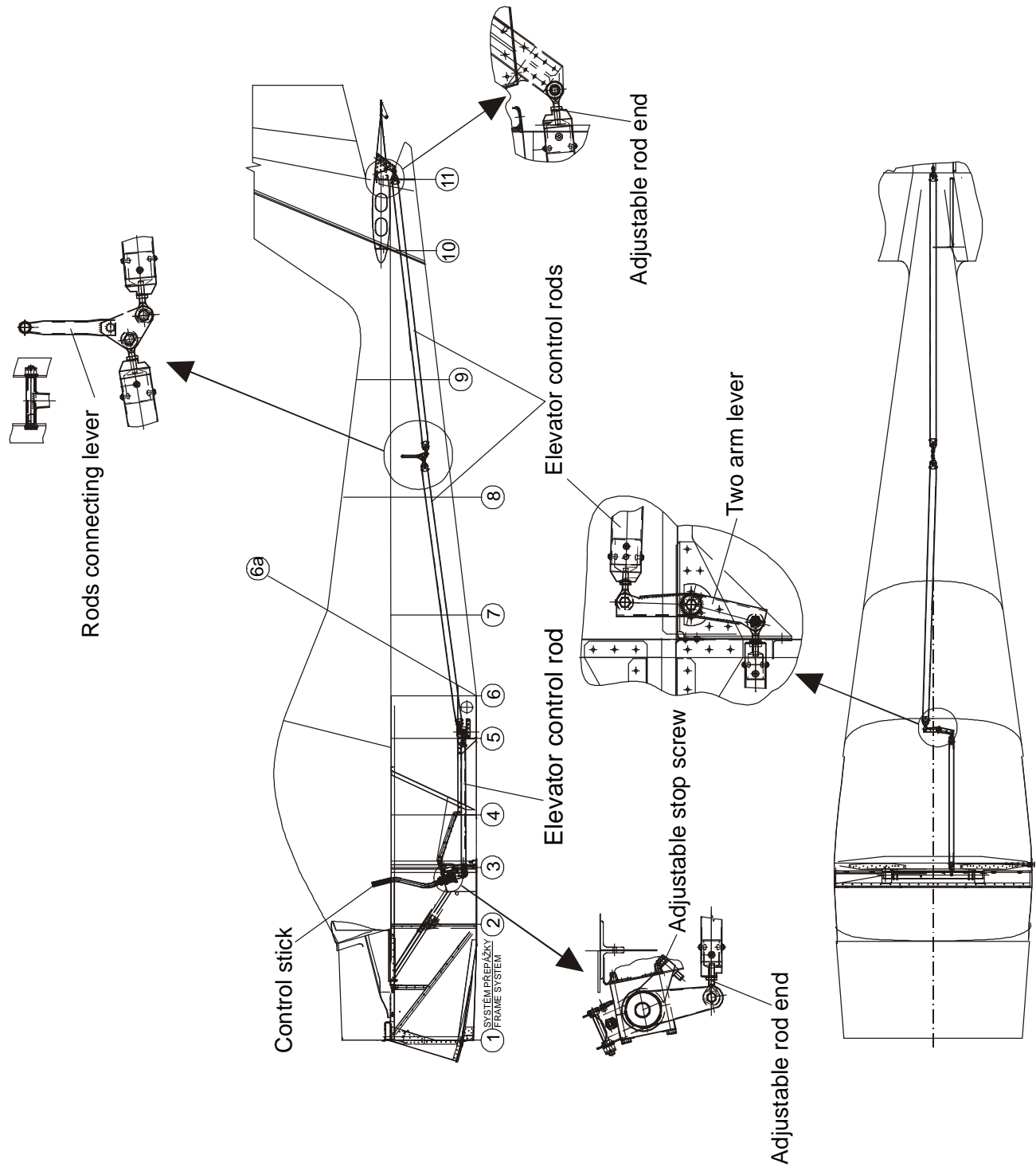



2.3.12.8 Lateral control system layout

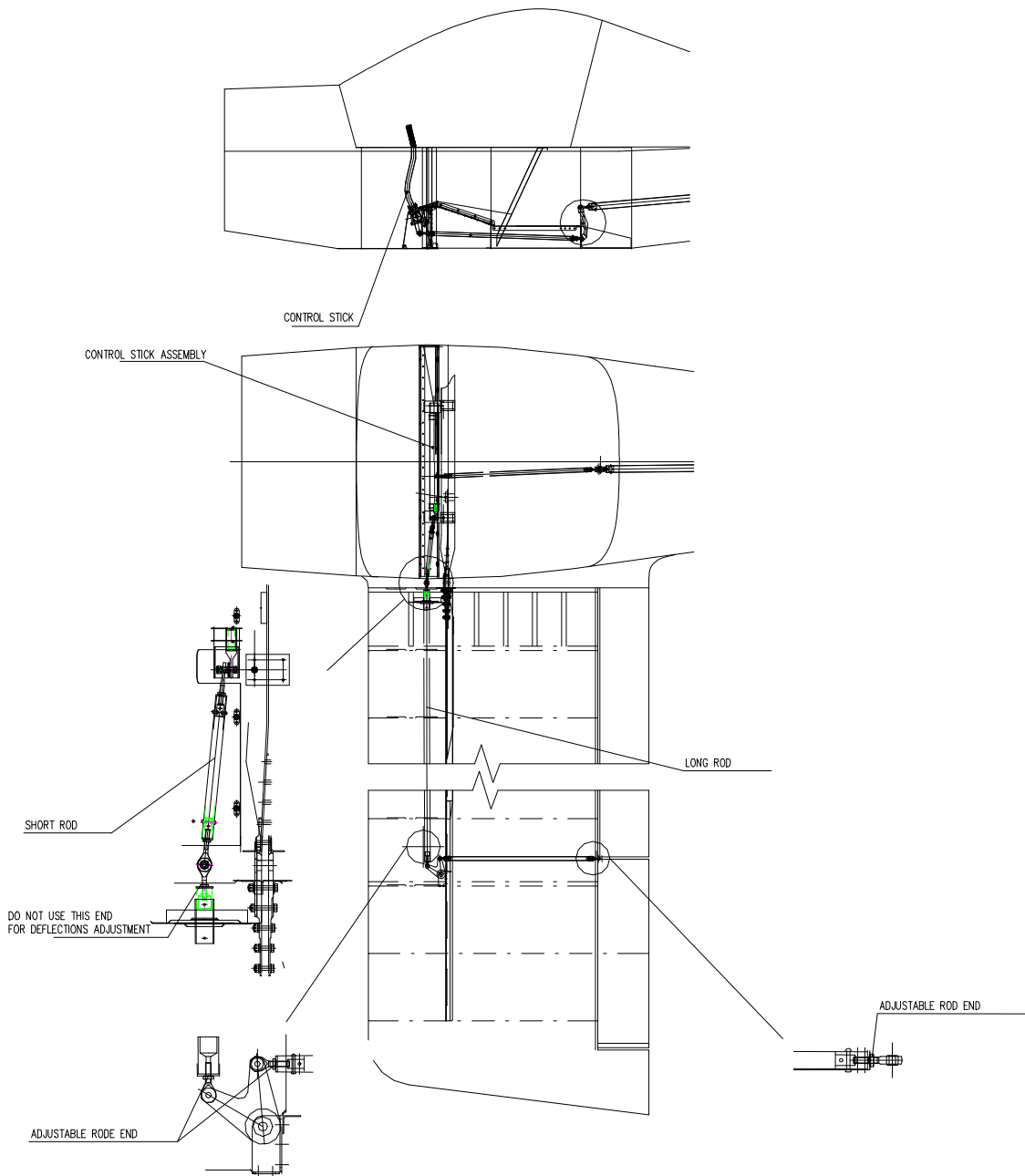



2.3.12.8.1 *Electric aileron trim tab control system layout (optional)*

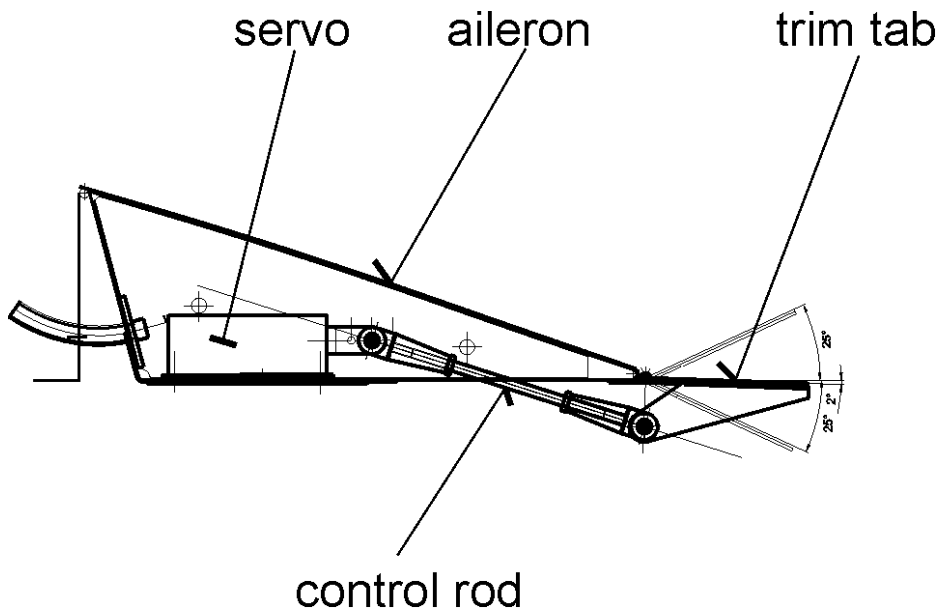



2.3.12.9 Directional control system layout

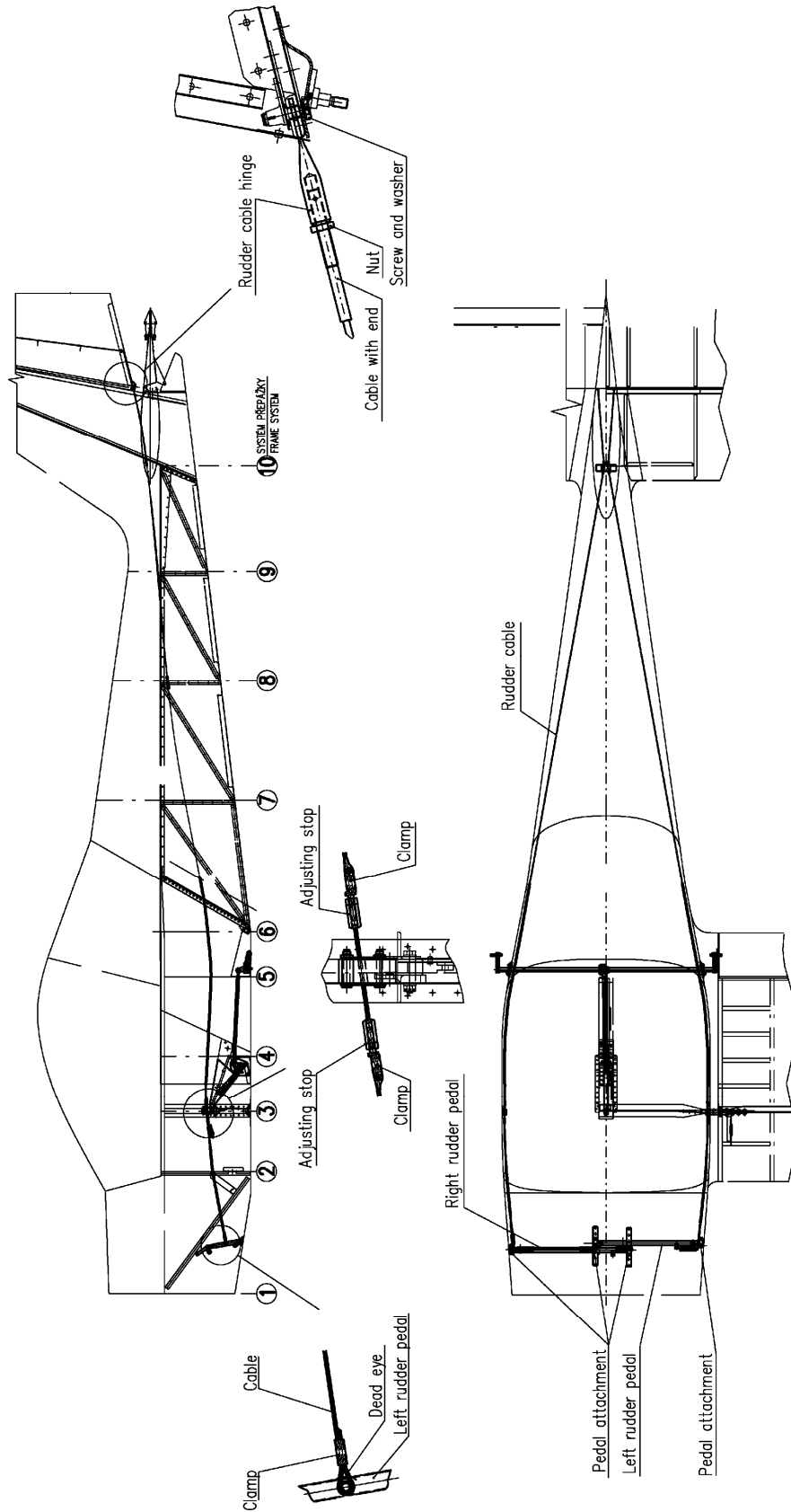



2.3.12.10 Flap control system layout

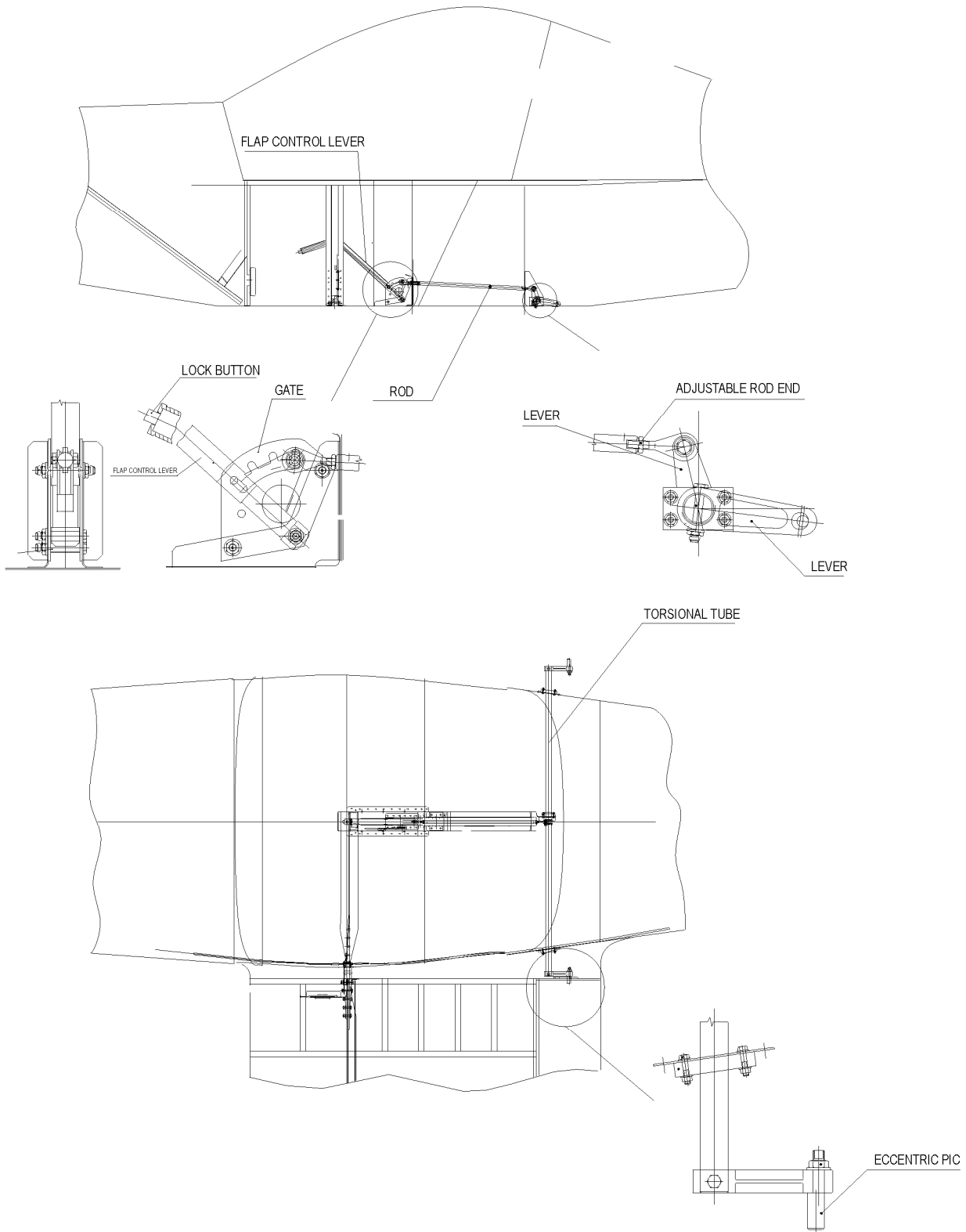



2.3.12.11 Elevator trim tab control system layout

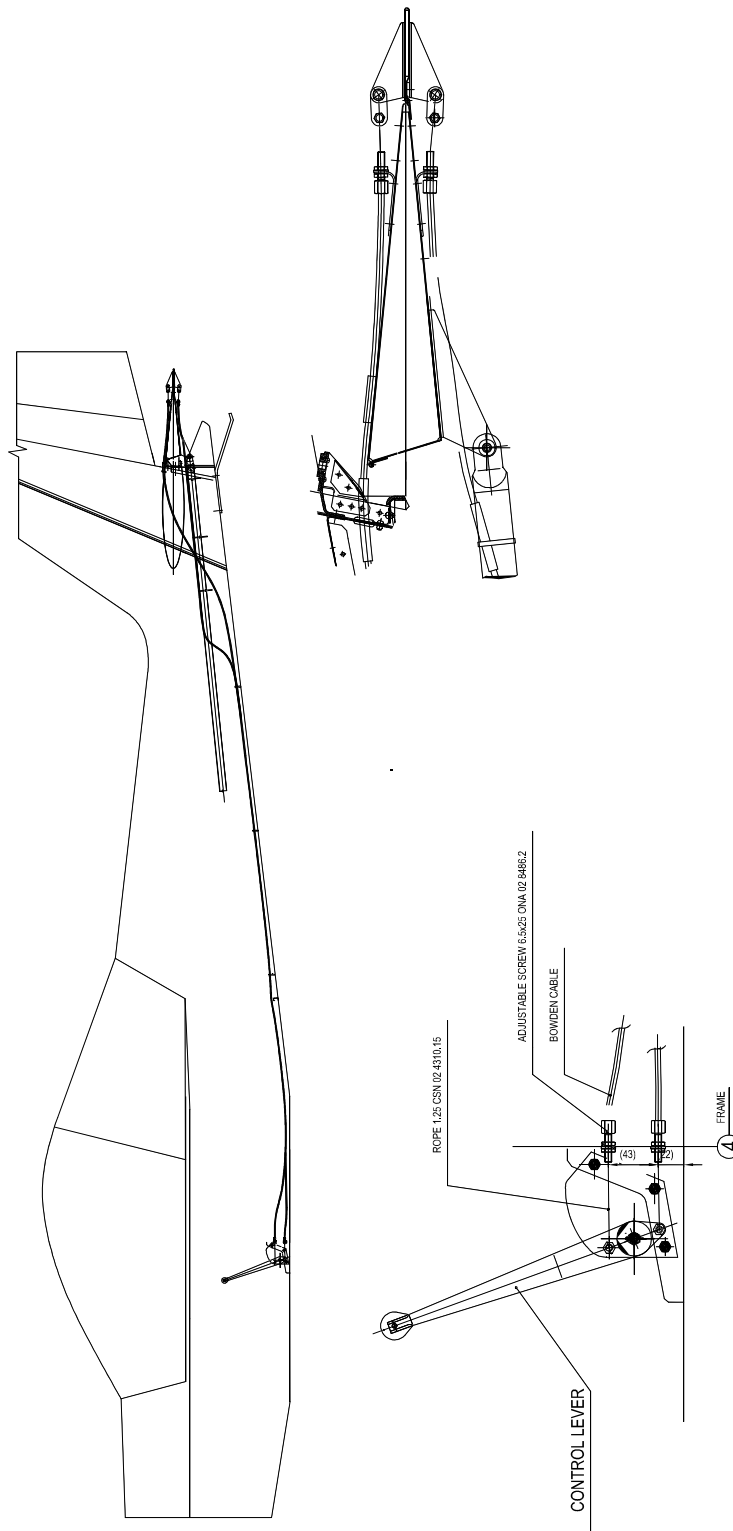



2.3.12.11.1 *Electric elevator trim tab control system layout (optional)*

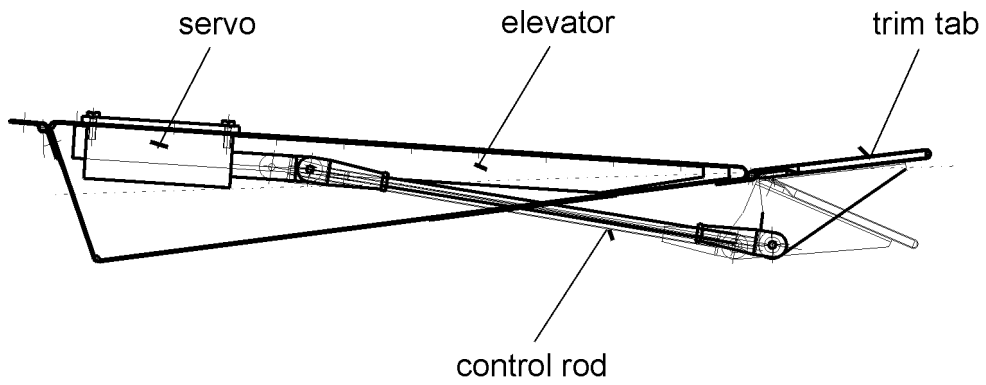



2.3.12.12 Nosewheel control system layout

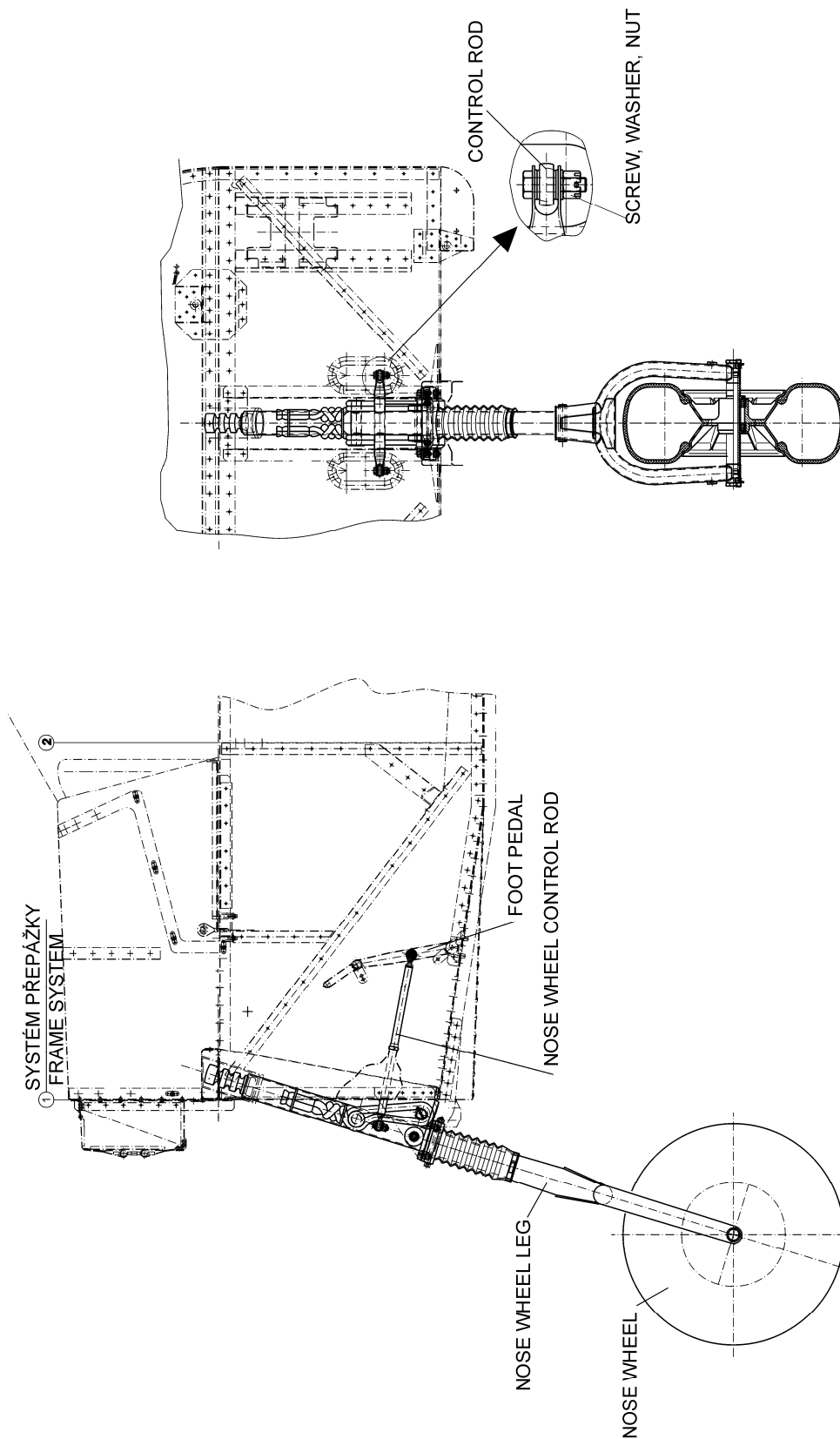



2.3.13 Powerplant

2.3.13.1 Brief description

The standard powerplant consists of the four-cylinder, 4 stroke, ROTAX 912 ULS engine and on-ground adjustable, 3 bladed, composite, WOODCOMP KLASSIC 170/3/R prop. Other props are optional.

IFR version is fitted with certified ROTAX 912S and ground adjustable, 3-bladed, composite Warpdrive CF prop, with Nickel protection of blade leading edges.

The engine data is scanned by an analog instruments or by integrated digital engine monitoring system EMS (optional).

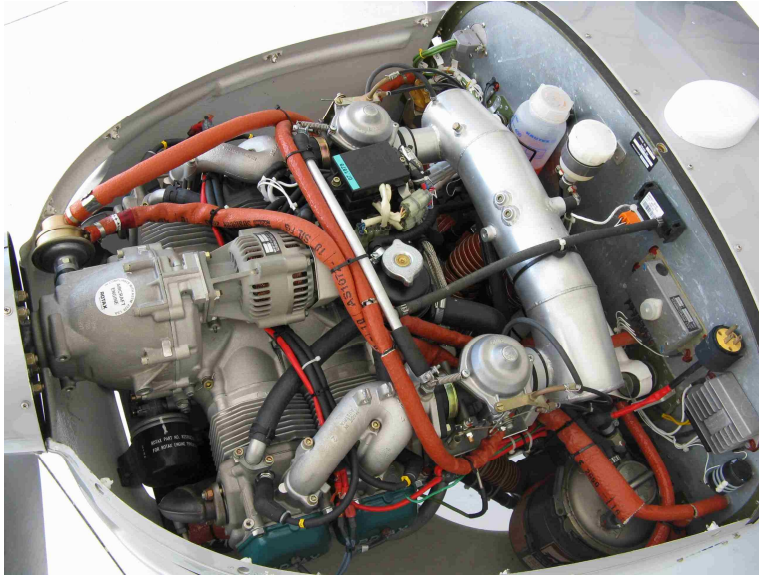

Fig. SportStar MAX Powerplant (optional Rotax 912S for IFR version)

2.3.13.2 Engine

2.3.13.2.1 Description

The Rotax 912 is a 4-stroke, 4 cylinder, horizontally opposed, spark ignition engine and has one central camshaft-push-rods-OHV.

Liquid cooled cylinder heads, ram air cooled cylinders.

Dry sump forced lubrication.

Dual breakerless capacitor discharge ignition.

The engine is fitted with electric starter, AC generator and mechanical fuel pump. Prop drive via reduction gear with integrated shock absorber.

Refer to the Rotax documentation for more details about different versions.

2.3.13.2.2 *Technical data*

Engine manufacturer:	Bombardier-Rotax GMBH	
Engine type:	ROTAX 912 ULS (S2 for IFR version)	
Power:	maximum take-off	73.5 kW / 100 HP
	maximum continuous	69 kW / 95 HP
Engine speed:	maximum take-off	5800 RPM max. 5 minutes
	maximum continuous	5500 RPM
	idle	1400 RPM
Cylinder head temperature:	maximum	275 °F
Oil temperature:	maximum	266 °F
	optimum operation	190 - 230 °F
Oil pressure:	maximum	102 PSI
	minimum	12 PSI
	optimum operation	29 - 73 PSI
Fuel pressure:	minimum	2.2 PSI
Fuel grades:	see 2.13,	
Oil grades:	see 2.14,	
Reducer gear ratio:	2.43 : 1	
Propeller:	Standardly installed:	IFR version:
Prop manufacturer:	WOODCOMP s.r.o.	Warpdrive
Propeller type:	KLASSIC 170/3/R 3 blade composite ground adjustable	Warpdrive CF Nickel protection of blade leading edges 3-bladed, composite Ground adjustable
Propeller diameter:	68 in	68 in
Maximum prop speed:	2600 RPM	2600 RPM



Fuel

The following fuels can be used :

	Usage / Description	
	912 UL / A / F	912 ULS / S
MOGAS		
European standard	EN 228 Normal ¹⁾	
	EN 228 Super ¹⁾	EN 228 Super ²⁾
	EN 228 Super plus ¹⁾	EN 228 Super plus ²⁾
Canadian standard	CAN/CGSB3.5 Quality 1 ³⁾	CAN/CGSB3.5 Quality 3 ⁴⁾
US standard	ASTM D4814	ASTM D4814
AVGAS		
US standard	AVGAS 100 LL (ASTM D910)	AVGAS 100 LL (ASTM D910)

¹⁾ min. ROZ 90

²⁾ min. ROZ 95

³⁾ min. AKI* 87

⁴⁾ min. AKI 91

AVGAS 100LL places greater stress on the valve seats due to its high lead content and forms increased deposits in the combustion chamber and lead sediments in the oil system. Thus it should only be used in case of problems with vapor lock or when other types of gasoline are unavailable.

- CAUTION: Use only fuel suitable for the respective climatic zone.
- ◆ NOTE: Risk of vapour formation if using winter fuel for summer operation.
- CAUTION: Obey the latest edition of Service Instruction SI-912-016 for the selection of the correct fuel.

Oil

Automotive engine oil of a registered brand with gear additives, but not aircraft oil (refer to Engine Operator's and Manual Service Information). API classification "SF" or "SG". Refer to para 4.6.1 and the Engine Operator's Manual and Service Information.



2.3.13.3 Propeller

2.3.13.3.1 Description

The WOODCOMP KLASSIC 170/3/R prop is installed in the SportStar MAX standardly. The prop is attached to the propeller hub with 6 bolts. A fiberglass spinner is used. Refer to the manuals supplied with the prop for more information.

Propeller Technical Data

Diameter.....	67	in	1700	mm
Pitch	on-ground adjustable, pitch 6-17°			
Weight.....	8.2	lbs	3.7	kg
Propeller blade clearance from ground.....	11.8 ± 1.2	in	300 ± 30	mm
Manufacturer	WOODCOMP, s.r.o.			
Kremen Sport Prop Junkers				
Czech Republic				
Vodolská 4				
250 70 Odolena Voda				

NOTE

The exact pitch/performance of the prop supplied with each airplane may differ slightly, therefore the exact performance of your airplane may be different.

IFR version is fitted with ground adjustable, 3-bladed, composite Warpdrive CF prop, with Nickel protection of blade leading edges.

NOTE

See Supplement No. 1 to this Aircraft Maintenance and Inspection Procedures for exact propeller installed on the airplane.



2.3.13.4 The EMS - engine monitoring system (if installed)

The Rotax 912ULS engine parameters can be monitored by an engine monitoring system like Dynon EMS D-120, TruTrak EMS, etc..
For engine parameters which are displayed refer to the manual supplied with such instrument.

2.3.13.5 Analog engine instruments

If analog engine instruments are installed then the instruments limit indicators should show the following:

Instrument	Units	Red line	Green arc	Yellow arc	Red line
		Lower limit	Normal operation range	Caution range	Upper limit
RPM indicator	RPM	-	1400 - 5500	5500 - 5800	5800
Oil temperature indicator	°F	-	190 - 230	120 - 190 230 - 266	266
Oil pressure indicator	PSI	12	29 - 73	12 - 29 73 - 102	102
Cylinder head temperature	°F	-	-	-	275

The following analog powerplant instruments are generally installed:

MITCHELL

- Engine speed indicatorMITCHELL P/N D1-211-5021
- Oil press indicatorMITCHELL P/N D1-211-5054
- Oil temperature indicatorMITCHELL P/N D1-211-5091
- Cylinder head temperature indicatorMITCHELL P/N D1-211-5082



2.3.13.6 Engine bed

2.3.13.6.1 Description

The engine bed is welded from chrome-molybdenum tubes and is attached to the firewall with 4 bolts. The bed is spring-mounted with four rubber silentblocks.



Fig. Engine bed
1- bed, 2 - rubber silentblock

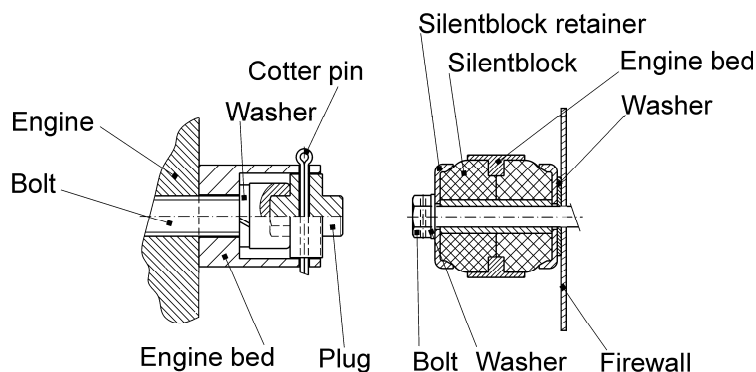

Fig. Engine bed suspensions



2.3.13.7 Engine cowlings

2.3.13.7.1 Description

There are two fiberglass cowlings (upper and lower) attached to the engine mount which cover the engine. The interior sides of the cowlings are protected with fireproof paint, exterior sides are painted with aircraft paint. The upper cowling is connected to the lower cowling with quick-closing locks and is usually removed for preflight inspections.

Removed engine cowlings are shown in the following figure.

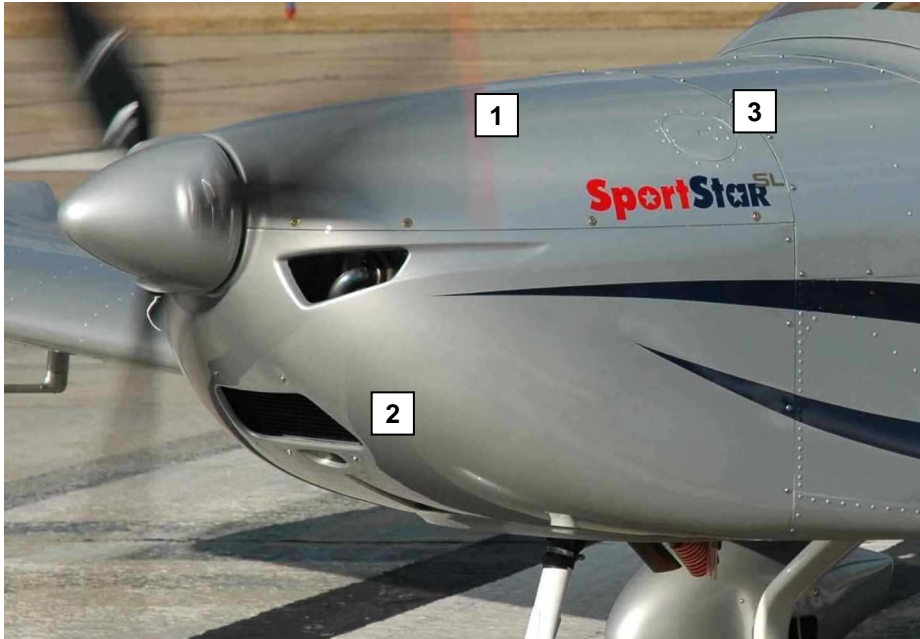

Fig. Rotax 912UL or 912S (ULS) engine cowlings
1- upper cowling, 2 - lower cowling with cut-out for the radiator,
3 - cap for oil level check

2.3.13.7.2 Engine cowlings disassembly and assembly

Type of maintenance: line.

Authorization to perform: - Aircraft owner (only for ELSA)
- Sport pilot
- or higher

Tools needed: Phillips screwdriver

Parts needed: none

Instructions:

- The upper cowling: The disassembly and assembly are both easy - just release the quick-closing locks. The upper cowling is usually removed during engine pre-flight inspection to check the engine compartment, operating fluids quantity (oil, coolant) and to check the engine installation.
- The lower cowling: To remove it, unscrew the attachment screws connecting the cooler to the cowling face side, then remove two air hose (unscrew sleeves) and then unscrew the attachment screws connecting the cowling to the firewall flange.

It is highly recommended to protect the removed cowlings so as to prevent them from inadvertent damage.

The cowling assembly is the reverse of disassembly.

Task proper accomplishment: check: check the screws are tight,
visually check the camlocks position.



2.3.14 Fuel system

2.3.14.1 Fuel system description

Fuel is contained in the wing integral tanks having approximately 60 liters (15.85 U.S. gallons) volume each. Each tank is fitted with air venting (output is under the wing tip) and draining valve on the bottom side of the wing. There are also single-way valves in the air venting system to avoid fuel leak through air vents in turns etc. Fuel is led from the tanks through the hoses to the fuel selector located on a central console under the instrument panel and then through a fuel filter to the engine pump and carburetors. Fuel return hose goes from the fuel pump into the left tank, which is due to considered as a primary" tank. See figure below for Scheme of fuel system.

The fuel tanks filler necks are placed on the upper side of the each wing. Fuel quantity is indicated by an electric fuel gauges or on a display of the engine monitoring system.

The drain valves are located on the bottom side of the each wing.

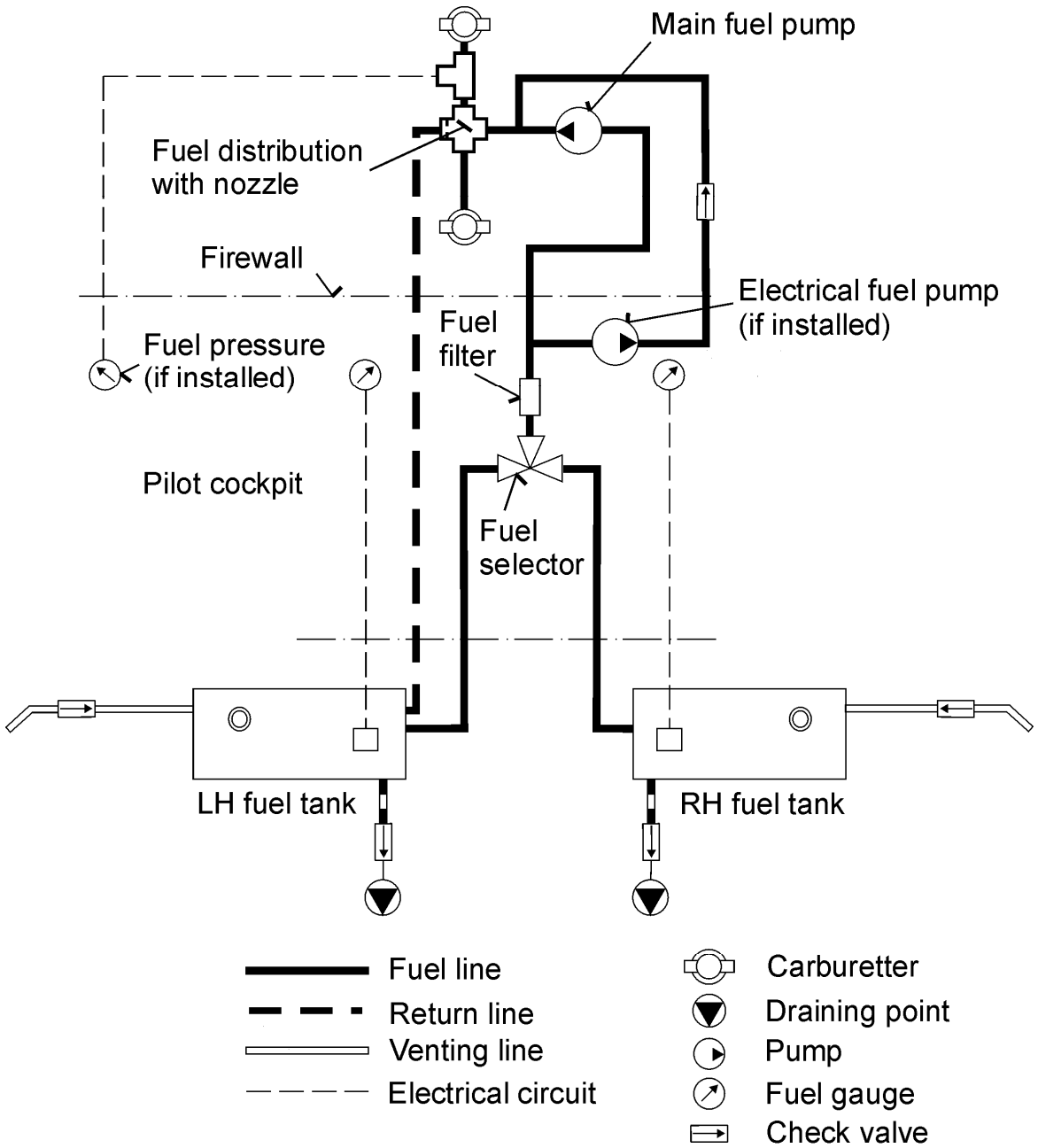



2.3.14.2 Standard fuel system layout

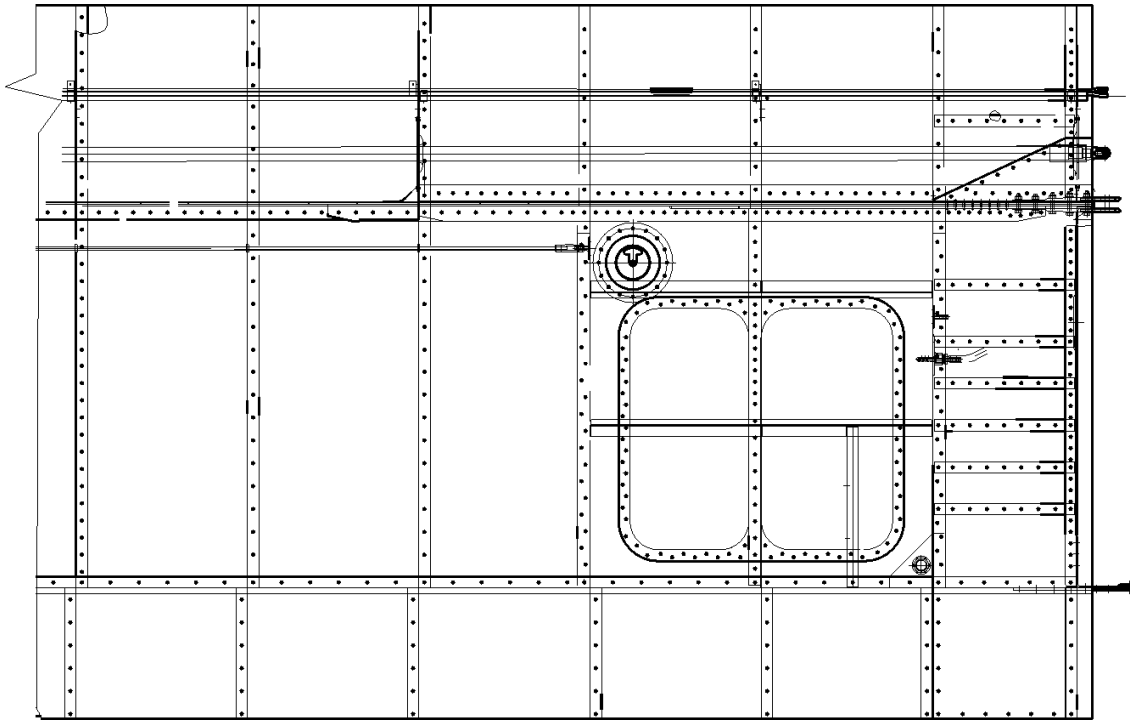



2.3.14.3 Fuel tank draining

Type of maintenance: line.

Authorization to perform: - Aircraft owner (only for ELSA)
- Sport pilot or higher

Tools needed: flat screwdriver
fuel resisting transparent bottle

Parts needed: none

Instructions:

The drain points of the fuel tanks are located at the bottom side of the wing.



Fig. Fuel drain valve

Procedure:

1. Put the suitable vessel or transparent cup under the drain valve.
2. Using screwdriver (or appropriate jig) press and turn draining valve to the left to open it.
3. Drain required quantity of fuel.

NOTE

Draining serves to elimination of impurities and deposits from the fuel. Drain until clean fuel flows from the drain valve.

4. Using screwdriver (or appropriate jig) turn draining valve to the right to close it.
5. Repeat procedure for the opposite tank.

WARNING

DO NOT SMOKE OR HAVE OPEN ANY FLAME DURING DRAINING!

Task proper accomplishment check: visually check, that the valve is closed and there is no leak of fuel through it.



2.3.15 Engine lubrication system scheme

2.3.15.1 Lubrication system description

The Rotax 912 engine is provided with a dry sump forced lubrication system. The oil pump pulls the motor oil from the oil tank attached to the firewall via the oil cooler. Then forces it through the oil filter to the lubrication points in the engine.

The surplus oil emerging from the lubrication points accumulates on the bottom of the crankcase and is forced back to the oil tank by the blow-by gases.

The oil tank is equipped with a vent hose.

The engine lubrication system is further described in documentation supplied with the engine.

2.3.16 Cooling system description

2.3.16.1 Cooling system description

The cooling system uses two forms of cooling. The cylinder heads are liquid cooled and the cylinders ram air cooled. The radiator is located in the front of the lower engine cowling. The coolant is forced through the radiator by a water pump, driven from the crankshaft to the cylinder heads. From the top of the cylinder heads the coolant passes on to the expansion tank which allows for coolant expansion. The expansion tank is closed by a pressure cap with an excess pressure valve and return valve. When the temperature rises the coolant creates excess pressure, a relief valve opens and the coolant flows through a thin hose to the overflow bottle mounted on the firewall. The engine cooling system is more completely described in documentation supplied with the engine.

Check the coolant level in the expansion tank (installed on the engine body) before the first flight of the day - replenish as required up to max. 2/3 of the expansion tank volume.

Check the coolant level in the overflow bottle (installed on the firewall) – coolant level volume should be at least approx. 0.42 pints (0.2 litre).



2.3.17 Heating

A cockpit heating system is optional.

2.3.17.1 Description

One air hose leads the air to the heat exchanger in the exhaust system where the air is heated up, then it is led through the valve at the firewall to the mixing chamber in the cockpit floor. When the valve is closed, the air is led through the outlet air hose under the aircraft.

The second air hose leads cold outside air directly through the valve at the firewall to the mixing chamber in the cockpit floor.

The hot air and cold air valves are operated by a cable from the heating valve/flap to a small push/pull knobs located on the instrument panel. Pull the knob to open the appropriate valve and bring air into the mixing chamber. The flap located in the mixing chamber allows air direction to the windshield or cockpit floor. The flap is operated with a knob located on the instrument panel.

The cockpit heating system is shown in the following figure:

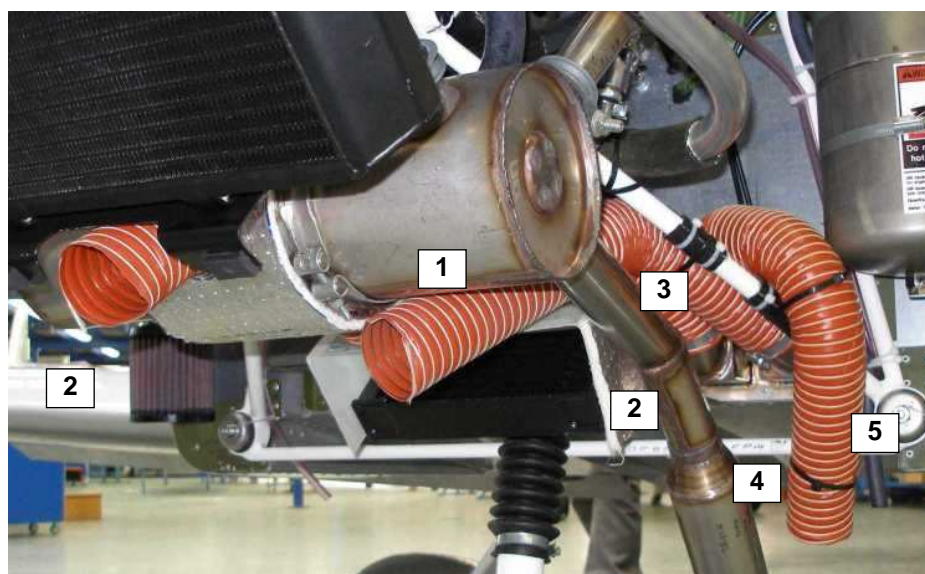

Fig. Cockpit heating system

1- muffler, 2 – hot air hose, 3 – outer air hose
4 - on the firewall mounted flaps, 5 – outlet hose

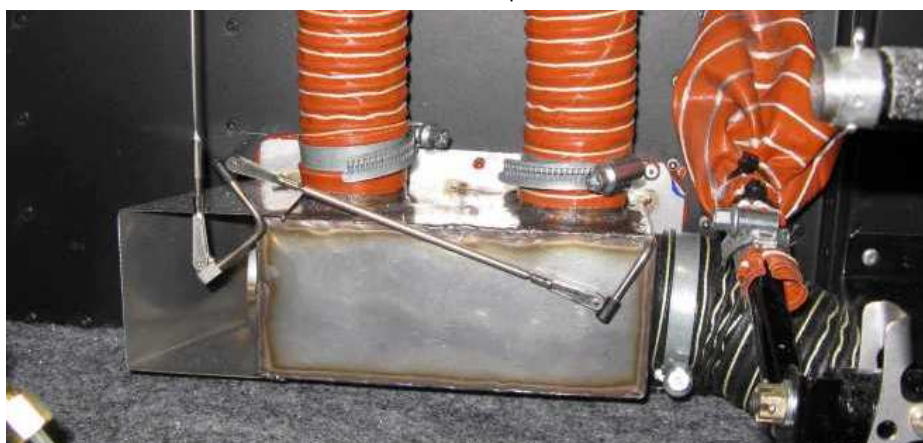

Fig. Heating mixing chamber



2.3.18 Ventilation

2.3.18.1 Description

Ventilation is ensured by 2 eye-ball vents located on the left and right of the tip-up canopy frame. Vents are connected to the NACA scoops through tip-up canopy frame front flaps. Defrosting of windshield and sides is ensured by hot air conducted from a cold/hot air mixing chamber on the firewall into the tip-up canopy frame and then through a row of holes onto the glass.



Fig. Eye-ball vent and holes for the canopy defog.



Fig. NACA scoop on the canopy



2.3.19 Wiring

2.3.19.1 Wiring description

The electric system is a single-wire type with the negative side connected to the chassis. The power source is a single-phase generator integral to the engine. A 12V/16Ah maintenancefree battery is located on the firewall.

Widely equipped airplanes (night VFR, IFR) are fitted with the auxiliary generator SD-20, mounted on the engine.

The system is protected by the main 30 Amp circuit breaker. The circuits of the particular sections are each guarded individually by circuit breakers.

The dual engine ignition is a separate part of the electrical system.

Piper type external power socket can be installed optionally. Socket is located on the right side of the fuselage, behind the firewall.

Optionally 12V automotive socket located on the instrument panel can be installed, as well as an another 12V socket behind the co-pilot seat, next to the headphones sockets.

2.3.19.2 Wiring diagram

The wiring system will vary and depends on the instrumentation, electronic equipment, and electric accessories of your aircraft.

See Supplement No. 1 to this Airplane Maintenance and Inspection Procedures to find wiring diagrams of your airplane.

2.3.19.3 Circuit breakers

The circuit breakers are located on the lower edge of instrument panel.

See Supplement No. 1 to this Airplane Maintenance and Inspection Procedures for circuit breakers detailed description of your airplane.



2.3.20 Pitot-static system

2.3.20.1 Pitot-static system description

The Pitot-static tube, located under the left wing near the aileron root, provides both total and static air pressure.

Pressure distribution to individual instruments is done through flexible plastic hoses.

Keep the system clear to ensure its correct function.

Both hose systems (Total and Static) are equipped with dirt pockets. The dirt pockets are located inside the cockpit on the floor in front of the pilot's seat.

IFR version is equipped with an alternate pitot-static tube located under the right half of the wing. This pitot serves only as a source of alternate static pressure. Both Primary and Alternate pitots are heated. There is a static pressure select knob located on the instrument panel to switch from Primary to Alternate static pressure.

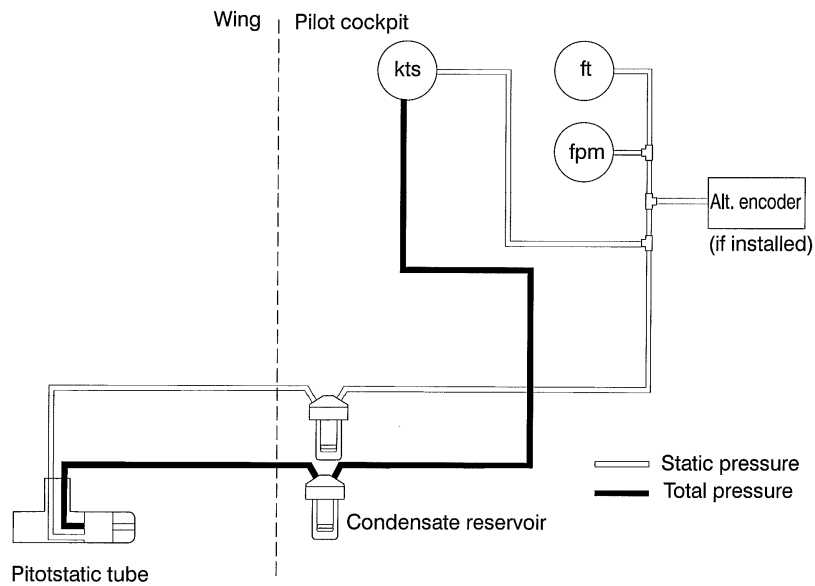

Fig. Standard pitot-static system

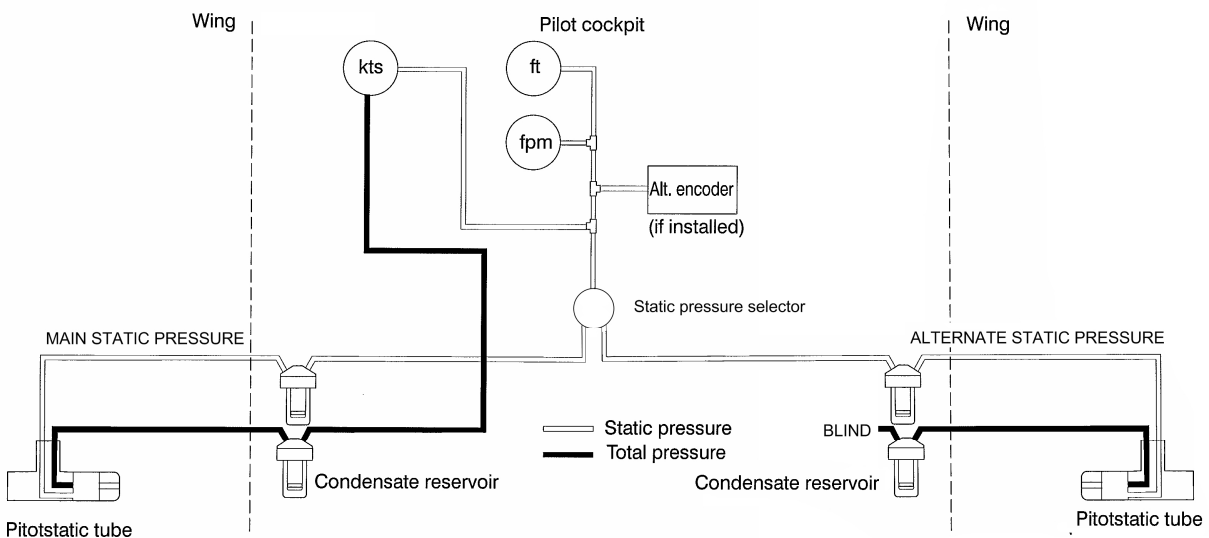

Fig. IFR pitot-static system



2.3.20.1.1 Pitot system draining

Type of maintenance: line, preventive

Authorization to perform: - Aircraft owner (only for ELSA)
- Sport pilot or higher

Tools needed: screwdriver to unscrew hand control cover(s) inside the cockpit

Parts needed: none

Instructions:

If water is visible inside the reservoirs from below the fuselage (see left figure below), then unscrew the hand control cover in front of the pilot seat to make access to the water reservoirs (right figure below). Screw the reservoirs off, dry, and slightly blow into the Pitot-static head. Then screw the reservoir covers back and check the packings.

CAUTION

Avoid blowing into the Pitot-static system with the dirt pocket cover is closed - it may cause an instrument malfunction.

Task proper accomplishment check: Check the dirt pocket covers are tight



Note: IFR version has 4 water reservoirs. 2 for the left wing primary pitot system, additional 2 for alternate pitot system for the right wing.

2.3.21 Placards

A new aircraft is equipped with placards supplied by the airplane manufacturer.

These placards explain the purpose of controls, instruments, airspeed limits, weight limits, etc. Placards with supplemental information such as a direction of handles are also supplied.

The placards are usually attached to the appropriate instruments and controls. Limitation placards are attached to the canopy, external placards are attached on the appropriate aircraft part, however placards may vary slightly from plane to plane.

CAUTION

The owner (aircraft operating agency) of the aircraft is responsible for the readability of placards during the aircraft service life.

2.3.21.1 Placards renewal

Type of maintenance: minor.

Authorization to perform: - Aircraft owner (only for ELSA)
- Sport pilot or higher

Tools needed: scissors

Parts needed: placards

Instructions:

In case of placard damage or unreadability, it is permissible to copy placards enclosed in the Appendices of these Procedures (copy on suitable adhesive tape) to replace the damaged placard.

Task proper accomplishment check: Check the new placards shows proper information, check it is properly attached.



3. OPERATION



3.1 Operation outlines

During operation of the **SportStar MAX** it is required to have in the following documentation in the plane (or according to appropriate aviation authority requirements):

- Aircraft Operating Instructions for **SportStar MAX** Light Sport Aircraft
- Aircraft Station Licence
- Certificate of Registration
- Certificate of Airworthiness
- Insurance Certificates
- Log Book (recommended)
- Other documents required by valid regulations and rules

However it is recommended to have on board other supplied manuals and documents e.g.:

- Aircraft Maintenance and Inspection Procedures for **SportStar MAX** Light Sport Aircraft
- Engine Operator's Manual
- Propeller Operator's Manual
- Additional documents supplied with instruments or equipment

The airworthiness and operational readiness of the airplane depends upon the careful adherence to the recommended procedures and regulations. Climate, aerodrome conditions, dustiness, manner of hangaring and other factors, such as the corrosive effects of industrial or seaside areas, should be considered.

The procedures given in this manual suit average operational conditions, more harsh environments may require more frequent maintenance intervals.



3.2 Airplane assembly

3.2.1 Wing

3.2.1.1 Wing assembly

The wing assembly procedure for an aircraft not-equipped with the optional wing folding mechanism is the following (3 persons are needed to accomplish this task):

3.2.1.1.1 Task information

Type of maintenance: heavy.

Authorization to perform:

- Repairman (LS-M) or Mechanic (A&P) – both with the minimum level of certification to perform heavy maintenance of SLSA in the U.S.
- FAA approved Part 145 Repair station

Tools needed:

- a hammer to move the wing suspension pins
- a screwdriver to attach wing fillets
- wrenches to tighten the rear wing suspension bolt nut

Parts needed: recommended grease

3.2.1.1.2 Wing-to-fuselage assembly procedure

The assembly procedure of one half of the wing is the following.

The procedure for both halves is similar.

1. Thoroughly clean and lubricate all the wing suspensions and bolts with a suitable lubricant before the assembly. Also lubricate the flap root groove.
2. The first person holds the wing tip, the second person holds the wing root leading edge, while the third holds the wing root trailing edge.

CAUTION

Take care of the pitot-static tube(s) when handling the wings.

3. Set the wing carefully on the wing attachments on the fuselage in such a way that the wing flap is set with the slot on the control pin. When sliding the wings on the attachments take increased care so that damage to hoses of pitotstatic system (left half of the wing) and electric system cables cannot occur.
4. Set the wing so that the attachments on the wing and on the fuselage are concentric.
5. The person keeping the wing on the leading edge will insert the pin into the upper main attachment (the pin head is in flight direction) and will insert the spacer with connected safety pin inside wing suspension (between rear eye and fuselage suspension). Shift pin by means of slight hammering to the stop (shifting can be facilitated by slight moving the wing tip up and down). Thereafter insert the pin into the lower main attachment and shift it by slight hammering to the stop.
6. Insert the bolt into the rear attachment of the wing and push it by slight hammering to the stop. Put the washer on the bolt and screw the nut on it. Secure the nut by means of the safety pin.
7. Put on the washers on the wing main attachment pins and secure the pins by cotter pins.
8. Connect the aileron control pull rod, secure the joint.
9. Connect fuel hoses to beaks on the fuselage and secure it with hose clip. Keep hose connection according to placards on the left side of the fuselage.
10. Connect wiring.
11. Install pitotstatic system hoses and carry out leakage test of the pitotstatic system.
12. Install wing fairings.

Task proper accomplishment check: Visually check that all pins are inserted and secured properly. Visually check the all control system joints are connected



3.2.1.2 Wing disassembly

3.2.1.2.1 Task information

Type of maintenance: heavy.

Authorization to perform:

- Repairman (LS-M) or Mechanic (A&P) – both with the minimum level of certification to perform heavy maintenance of SLSA in the U.S.
- FAA approved Part 145 Repair station

Tools needed:

- a hammer to tap the wing suspension pins out
- a screwdriver to unscrew the wing fillet connection screws
- wrenches to unscrew the rear wing suspension bolt nut
- a drift made from duralumin round or other suitable material (diameter 10-12 mm) to drive out the wing suspension pins

Parts needed: none

3.2.1.2.2 Wing-from-fuselage disassembly

1. Remove the fuselage-wing fairings.
2. Drain all fuel from tanks. Push airplane tail down (almost to the ground) to allow drain of the all unusable fuel.
3. In case of dismatling the left half of the wing disconnect hoses of pitotstatic system.
4. Disconnect fuel hoses from beaks on the fuselage
5. Disconnect cable plugs and sockets of electrical system.
6. Disconnect aileron control pull rod.
7. The first person will lay hold on the wing tip, the second person by the root on the leading edge, the third person by the root on the trailing edge.
8. Push out the safety pin securing the crown nut of the rear pin and dismantle the rear pin of the wing attachment.
9. Release pins (push out the cotter-pins) on the main atatchments of the wings.
10. Release the wing by slight lifting the wing tip upwards.
11. By meas of hammer and round timber knock out the lower and the upper pin from the main wing attachments.
12. By pulling the wing in direction from the fuselage, disconnect the wing from the fuselage.
13. Position the disconnected wing in such a way that its damaging cannot occur.

Task proper accomplishment check: Check that nothing was damaged on the airplane due to wing removal.



3.2.2 *Horizontal tail unit*

Type of maintenance: heavy.

Authorization to perform:

- Repairman (LS-M) or Mechanic (A&P) – both with the minimum level of certification to perform heavy maintenance of SLSA in the U.S.
- FAA approved Part 145 Repair station

Tools needed:

- a wrench for M8 nuts
- a screwdriver for the tail unit/fuselage fairing

Parts needed: recommended grease

3.2.2.1 HTU-from-fuselage disassembly

1. Unscrew attachment bolts of HTU-fuselage fiberglass cover.
2. Disconnect the trim tab control cables.
3. Disconnect the elevator control rod.
4. Remove the safety pins securing the castle nuts on the bolts of the stabilizer rear suspensions. Screw off the nuts and remove the washers.
5. Draw the HTU out of the fuselage.
6. Put connecting components in a safe place to avoid losing them.

3.2.2.2 HTU-to-fuselage assembly

3.2.2.2.1 *Necessary tools*

3.2.2.2.2 *HTU-to-fuselage assembly*

1. Make the connecting components ready, clean and lubricate HTU suspensions.
2. Insert the HTU from the rear into the fuselage as far as the stabilizer will go into the two pins in the front, and the two bolts (M8) in the rear. Take care of the trim tab control cables.
3. Put the washers on the M8 bolts. Screw on the castle nuts, and secure with a safety pins.
4. Attach the HTU/fuselage fairing using screws.
5. Insert the M8 bolt to connect the elevator control hinge with the control rod. Put on a washer, and self-locking nut.
6. Connect trim tab control cables.
7. Adjust the elevator and trim tab deflections (see 3.4.6)

Task proper accomplishment check:

- check proper attachment of trim control cables (upper cable to trim upper surface)
- check HTU proper attachment and securing of all joints
- check elevator and trim tab deflection



3.2.3 Vertical tail unit

3.2.3.1 Assembly and Disassembly of the rudder

3.2.3.1.1 Task information

Type of maintenance: heavy.

Authorization to perform:

- Repairman (LS-M) or Mechanic (A&P) – both with the minimum level of certification to perform heavy maintenance of SLSA in the U.S.
- FAA approved Part 145 Repair station

Tools needed:

- a wrench to tighten/remove the M5 nut

Parts needed: none

3.2.3.1.2 Rudder-from-fuselage disassembly

1. Disconnect the rudder control cables, attach the ends of the cables together to keep the cables from slipping inside the fuselage.
2. Remove the safety pin from the lower suspension bolt. Remove the castle nut and washer.
3. Lift and remove the rudder from suspensions

3.2.3.1.3 Assembly procedure

1. Put the rudder on the fin suspensions from above. Use care not to move the spherical bearings in the rudder suspensions.
2. If necessary insert a washer to adjust lower suspension clearance.
3. Put the washer on the lower suspension bolt, tighten the castle nut and secure with a safety pin. Attach the rudder control cables. Use tab washers to secure bolt heads.

Task proper accomplishment check: check securing of all joints.



3.2.4 Landing gear

Type of maintenance: line.

Authorization to perform: - Aircraft owner (only for ELSA)
- Sport pilot or higher

Tools needed:

- flat screwdriver
- allen wrench No. 6

Parts needed: none

3.2.4.1 Disassembly of wheel pants

Instructions:

Main wheel pants are attached with 3 bolts to a bracket mounted on the main landing gear leg and with one bolt from outside to the wheel axle.

1. Remove 3 bolts attaching the wheel pant from inner side to the bracket.
2. Remove the bolt attaching the wheel pant to the wheel axle.
3. The nose landing gear wheel pant consists of two parts. The rear part is attached by two bolts to the brace on the landing gear leg and by another two bolts to the braces on the landing gear fork. The front part of the wheel pant is bolted by 10 bolts to the rear part of the wheel pant. Remove 10 bolts connecting both parts of the wheel pant.
4. First remove two side bolts on the rear wheel pant and then two bolts on the upper side of the wheel pant.

3.2.4.2 Assembly of wheel pants

When assembling the main landing gear wheel pant, proceed as follows:

1. Set the wheel pant to position and bolt it with 3 bolts to the bracket.
2. From outside insert the bolt with washer into the hole in the wheel pant. From inner side of the wheel pant shift the spacing tube on the bolt and screw the bolt into nut hole in the wheel center. Secure the bolt head with locking wire in order to prevent from its turning.
3. At assembling the nose wheel pant proceed in the following way:
4. By using two bolts with washers attach the rear part of the wheel pant to the brace on the nose landing gear leg. Attach the wheel pant on the sides with two remaining bolts with washers to the braces on the landing gear fork.
5. Shift the front part on the rear part of the wheel pant and join both parts using 10 bolts with washers.

Task proper accomplishment check: check tightening of bolts and securing of bolt head by wire

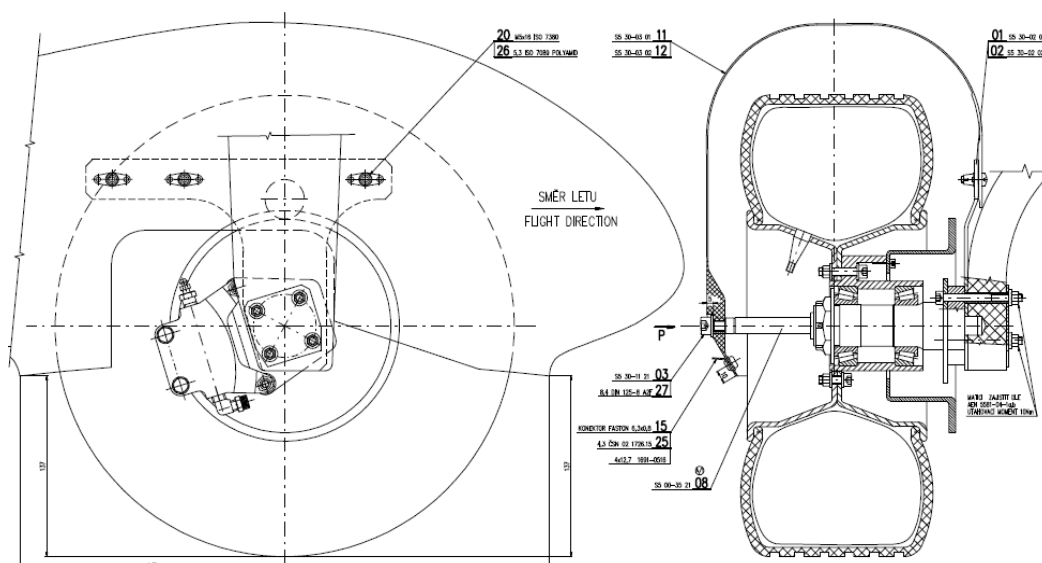

Fig. MATCO main wheel and brake



3.2.4.3 Disassembly of nose landing gear wheel

Type of maintenance: heavy.

Authorization to perform:

- Repairman (LS-M) or Mechanic (A&P) – both with the minimum level of certification to perform heavy maintenance of SLSA in the U.S.
- FAA approved Part 145 Repair station

Tools needed:

- a support
- cut pliers
- flat screwdriver
- allen wrench No. 6

Parts needed: recommended grease
locking wire

Instruction

1. Jack and support the airplane.
2. Disassemble the nose landing gear wheel pant.
3. Cut the locking wire securing side screws.
4. Disassemble one side screw.
5. Release the wheel axle from the wheel hub and the fork eyes.

3.2.4.4 Assembly of nose landing gear wheel

Instruction:

1. Clear the wheel axle of impurities and grease it slightly.
2. From one side shift the axle into the landing gear leg fork eye.
3. Gradually put on the long spacer, shim, nose wheel, shim and short spacer on the wheel axle according to the figure (from the right in the flight direction).
4. From both sides screw and tighten screw in the wheel axle.
5. Check for free turning of the nose wheel (turning must be continual without catching).
6. Secure side screw with locking wire to prevent from their releasing according to figure.
7. Reassemble the wheel pant.

Task proper accomplishment check: check free rotation, no clearance, securing of screw heads.

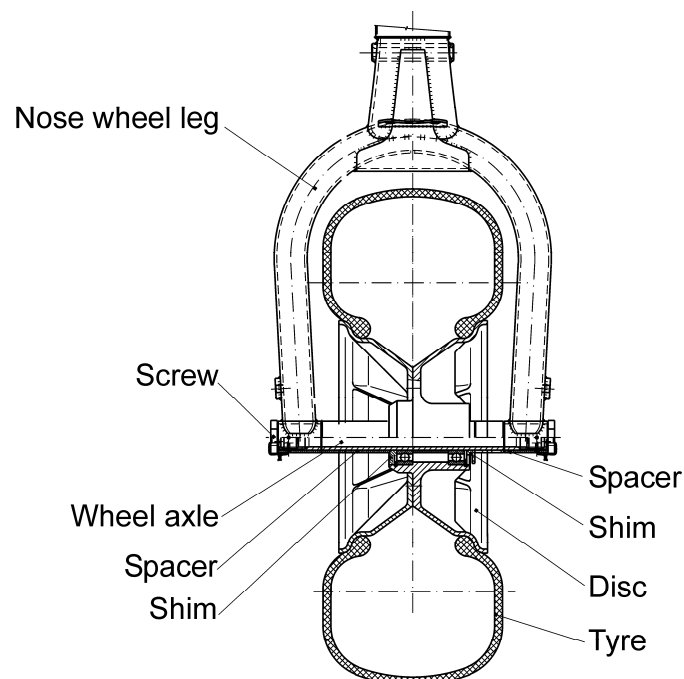



3.2.4.5 Disassembly of main landing gear wheel

Type of maintenance: heavy.

Authorization to perform:

- Repairman (LS-M) or Mechanic (A&P) – both with the minimum level of certification to perform heavy maintenance of SLSA in the U.S.
- FAA approved Part 145 Repair station

Tools needed:

- a support
- flat screwdriver
- nut wrench

Parts needed:

- recommended grease
- locking wire

Refer to the *MHE6B & MHE6B-C External caliper, 6" E- Series, Wheel and Brake, I. MHME6B Wheel Assembly Instructions*

available at <http://matco.veracart.com/pdf/MHE6BMANUALp.pdf?lit=2411&lct=23>

3.2.4.6 Assembly of main landing gear wheel

For the assembly of the MATCO MHME 6B1.25 main wheel refer to the *MHE6B & MHE6B-C External caliper, 6" E- Series, Wheel and Brake, I. MHME6B Wheel Assembly Instructions*

available at <http://matco.veracart.com/pdf/MHE6BMANUALp.pdf?lit=2411&lct=23>

Task proper accomplishment check: check free rotation of wheel, no clearance, securing of screws.

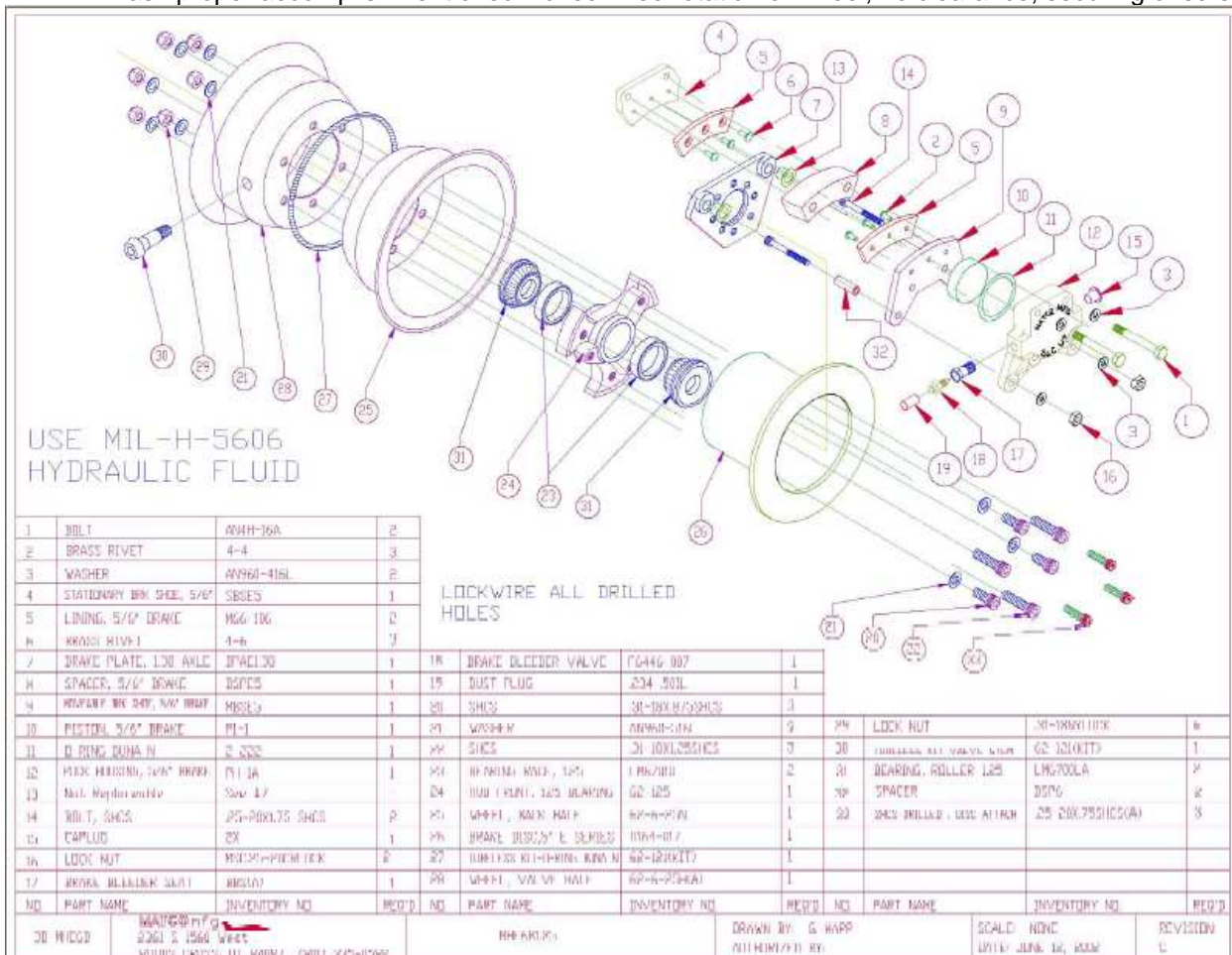

Fig. MATCO wheel assembly diagram



3.2.5 Cockpit canopy

Type of maintenance: line.

Authorization to perform:

- Aircraft owner (only for ELSA)
- Sport pilot or higher

Tools needed:

- Phillips screwdriver
- pincers
- nut wrench No. 9 and 10

Parts needed: none

3.2.5.1 Canopy demounting

The front portion of the canopy can be removed, while the rear portion is fixed. The front section of the canopy is attached to the fuselage with two screws. The weight of canopy is counter-balanced with two gas struts inside the cockpit. Use the following procedure to remove the front canopy:

1. Remove cover above the dashboard in front of the canopy. Use Phillips screwdriver to unscrew all screws which attach the cover.
2. Open fully the canopy and fix it in open position. Help of another person is useful.
3. Use pincers or another useful tool to remove safety wire from the gas strut ball end. Repeat this on opposite side of the canopy
4. Fix or hold canopy open and carefully remove gas strut ends from the canopy.
5. Use nut wrench M9 to release and unscrew nuts from the canopy attachments bolts.
6. Remove the bolts and washers
7. Remove carefully the canopy and put it on a safe place to not be damaged

Pictures below illustrate canopy attachment.

3.2.5.2 Canopy mounting

The Mounting procedure is the reverse.

Task proper accomplishment check: Check proper attachment of canopy, open and close it. Check if it may be locked in closed position.

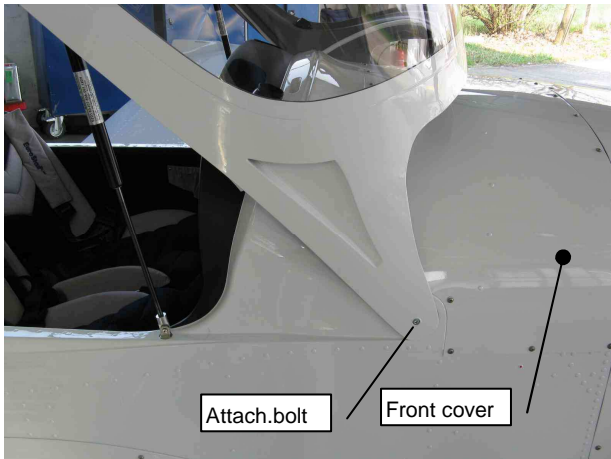

Fully opened canopy



Canopy attachment bolts

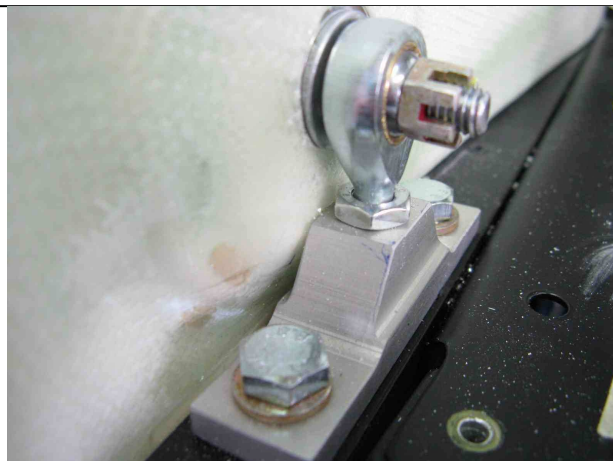

Canopy attachment

3.2.6 *Installation and reinstallation of instruments*

Type of maintenance for the pitot static instruments: heavy.

Authorization to perform:

- Repairman (LS-M) or Mechanic (A&P) – both with the minimum level of certification to perform heavy maintenance of SLSA in the U.S.
- FAA approved Part 145 Repair station

Type of maintenance for the other instruments: line.

Authorization to perform:

- Aircraft owner (only for ELSA)
- Sport pilot or higher

Tools needed:

- flat screwdriver
- other tools according to installed instruments

Parts needed: Refer to manuals supplied with particular instruments

Instructions:

The installation procedure will depend on the instrument being installed. Follow the manufacturer recommendations (manuals supplied with particular instruments).

Ordinarily, there is no need to remove the instrument panel when installing or removing an instrument. Remove the instrument attaching screws and remove the instrument from the back of the instrument panel (after disconnection of appropriate wires or hoses). If it is necessary to gain access to the instrument wiring, remove the sheet cover over the instrument panel.

Task proper accomplishment check: Refer to manuals supplied with particular instruments



3.3 Leveling

Type of maintenance: heavy.

Authorization to perform:

- Repairman (LS-M) or Mechanic (A&P) – both with the minimum level of certification to perform heavy maintenance of SLSA in the U.S.
- FAA approved Part 145 Repair station

Tools needed:

- jacks to lift and level the aircraft
- level instrument
- roll meter

Parts needed: none

Instructions:

Leveling is used to check the airframe alignment.

First set the aircraft in a horizontal position (use boards) according to leveling points. The leveling points are the rivets on the aircraft which are (generally) marked with red paint. The location of the points is shown in the Leveling Record. Use the leveling points 1(3) and 2(4) to set the airplane in a horizontal position in longitudinal direction, and leveling points 5 and 7 in lateral direction.

Boards, under the main or nosewheel, may be used to level the airplane. The best way to measure a leveling point height is to use a level. Alternatively a running meter is sufficient for approximate measurement.

Measured values should be recorded in the Leveling Record (see Appendices). Height differences between corresponding leveling points have to be calculated. A check must than be carried out to prove that any differences do not exceed the tolerances permitted in the Leveling Record.

If any difference exceeds the permitted tolerance, the aircraft assembly, plays in hinges and eventual permanent deformations, should be inspected.

The aircraft manufacturer should be contacted in serious cases.

Task proper accomplishment check: Compare measured values with those ones prescribed in leveling record.



3.4 Measurement of control surfaces deflections

Type of maintenance: line.

Authorization to perform: - Aircraft owner (only for ELSA)
 - Sport pilot or higher

Tools needed:

- protractor with deflecting hand
- a clamp to fix protractor on control surface

Parts needed: none

Task proper accomplishment check: Compare measured deflections with those ones prescribed in Control surfaces deflection record.

3.4.1 Required deflections

The deflection of the control surfaces are specified in the Control Surfaces Deflection Record (see Appendices of this Manual) and in the following Figure. A protractor with deflecting hand is used by the airplane manufacturer to measure deflections. The protractor is attached to a control surface with a hand clamp. There are also alternative procedures in the following text.

Aileron

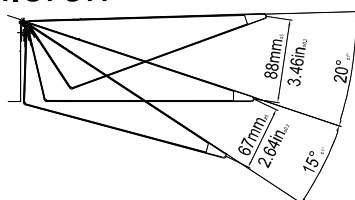

Flaps

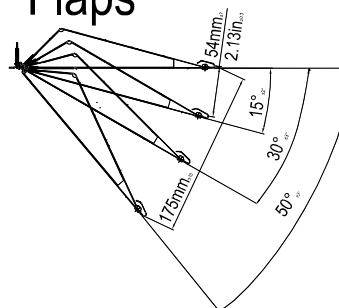

Elevator

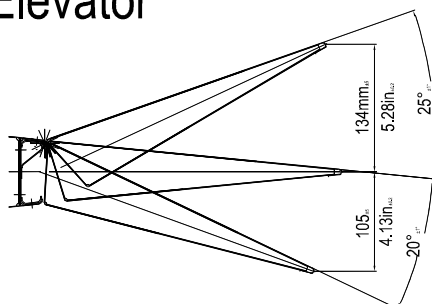

TrimTab

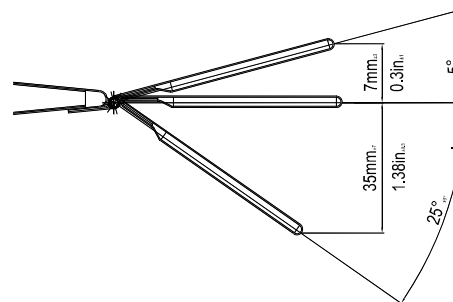

Rudder

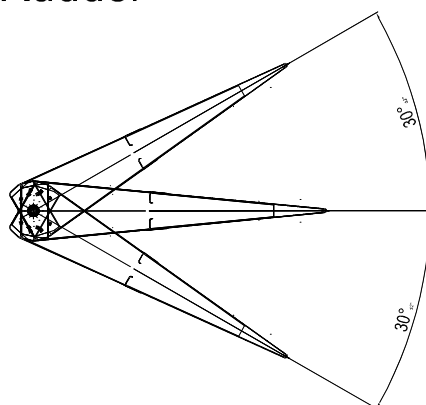



3.4.2 Aileron deflection measurement

Measurement procedure:

1. Attach a protractor with a deflection hand at the aileron upper surface by means of a clamp.
2. Set the aileron in neutral position (the aileron must fit the wing profile).
3. Zero the protractor - starting position for measurement .
4. Deflect the aileron fully down/up and note the deflections.
5. Compare, the measured deflections with the ones specified in the Control Surfaces Deflection Record. If required - adjust the aileron deflection according to par. 4.11.1 .

If a protractor is not available, the following procedure may be substituted:

1. Insert a stiff cardboard sheet of paper in the space between the aileron and the flap. Hold the drawing paper against the flap.
2. Put the aileron in a neutral position. Then trace its profile (upper surface from the hinge to the trailing edge). Then trace the profile of the aileron fully deflected in both directions.
3. Remove the drawing paper and measure the deflection from the neutral position using a protractor.
4. Compare the measured deflections with those specified in the Control Surfaces Deflection Record. If required - adjust the aileron deflection according to 4.11.1.

3.4.3 Flap deflection measurement

The wing flaps can be set in 4 positions: RETRACTED, TAKEOFF, LANDING (2 positions).

Measurement procedure:

1. Cut a strip of aluminium sheet 2 inches (50 mm) wide. The strip is than attached to the flap lower surface with two bolts (somewhere in the middle of the flap span where two nuts are riveted). The strip should overhang the flap trailing edge.
2. Attach a protractor with a deflection hand at the strip using a clamp.
3. Zero the protractor - this will be the starting position for measurement with the flaps retracted
4. Extend the flap to the required position using the flap control lever and read the deflection
5. Compare the measured deflections with those specified in the Control Surfaces Deflection Record. If required - adjust flap deflection according to the par. 4.11.2.

If a protractor is not available, the following procedure may be substituted:

1. Insert a stiff cardboard sheet of paper in the space between the aileron and the flap. Hold the drawing paper against the flap.
2. Trace the profile of the retracted flap on the lower surface from the hinge to the flap trailing edge)
3. Move the flap to an extended position and trace the lower surface profile again
4. Remove the drawing paper and measure the deflection from the "RETRACTED" position using a protractor
5. Compare the measured deflections with those specified in the Control Surfaces Deflection Record. If required - adjust flap deflection according to the par. 4.11.2.



3.4.4 Elevator deflections measurement

The starting position to measure the elevator deflections is the neutral positions of the control stick and elevator. The neutral position of the control stick is set by the aircraft manufacturer, by means of a jig. The distances between the control stick and instrument panel, and between the control stick and fuselage side can be used to set the neutral position. When the elevator is in the neutral position, the chord of the Horizontal tail unit will be parallel to upper edge of the fuselage side (lower frame of the cockpit).

Measurement procedure:

1. Attach a protractor with a deflection hand at the elevator trailing edge
2. Set the elevator to the neutral position
3. Zero the protractor
4. Fully pull or push the control stick to deflect the elevator and read the deflection
5. Compare the measured deflections with those specified in the Control Surfaces Deflection Record. If required - adjust elevator deflection according to the par. 4.11.3.

If a protractor is not available, the following procedure may be substituted:

1. Support the airplane under the tail skid and firewall and set the airplane in a horizontal position (a level set on the canopy lower frame can be used to set the airplane in horizontal position)
2. Stand a suitable staff close to the elevator trailing edge and mark the neutral position of the elevator.
3. Move the control stick and fully deflect the elevator. Mark the positions of the elevator while fully deflected
4. Measure the distances between marks on the staff
5. Compare the distances with those specified in Fig. 3.4.1. If required - adjust elevator deflection according to the par. 4.11.3.

3.4.5 Rudder deflection measurement

The rudder deflections are set by the aircraft manufacturer. If necessary the rudder deflections can be adjusted by adjustable stops located on the rudder control cable in the cockpit (see figure on page 2-24).

A measuring instrument is used by the aircraft manufacturer to measure the rudder deflections. The instrument is put on the vertical tail unit and a rudder deflection may be read directly.

The rudder deflection may be measured however, when the set the rudder is set to the neutral position. Stand a suitable staff at the ruder trailing edge and mark lower edge of the rudder. Fully deflect the rudder and measure using a ruler between the mark on the staff and the lower edge of the rudder. Compare the measured distance with that specified in 3.4.1.



3.4.6 Trim tab deflections measurement

The trim tab deflection is measured from the neutral position. When the trim tab profile does not protrude from the elevator profile with elevator set in neutral position.

Measurement procedure:

1. Attach a protractor with a deflection hand at the trim tab
2. Neutralize the trim tab and the elevator
3. Zero the protractor
4. Set the trim tab in maximum lower or upper position using the trim tab control lever and read the deflection from the protractor scale.
5. Compare the deflection with that specified in the Control Surfaces Deflection Record. If required - adjust trim tab deflection according to the par. 4.11.5.
6. Check tension of trim tab control cables according to the following procedures:
Block elevator against to movement and trim tab control lever set to the neutral position. Apply a load of 20 N (preferably according to a dynamometer) to the trim tab trailing edge. The trim tab deflection must not exceed value of 5^{+2} mm from the original position. If the trim tab deflection exceeds this value, then it is necessary to adjust trim tab cable preload by adjusting screws.

If a protractor is not available, the following procedure may be substituted:

1. Insert a stiff cardboard sheet of paper in the space between the elevator and the trim tab and hold the cardboard against the elevator.
2. Trace the profile of the neutralized trim tab
3. Move the trim tab to the maximum (both directions) using the trim tab control lever and trace the profile again
4. Remove the cardboard and measure the deflection from the neutral position using a protractor
5. Compare the deflection with that specified in the Control Surfaces Deflection Record. If required - adjust trim tab deflections according to the par. 4.11.5.
6. Check tension of trim tab control cables according to the following procedures:
Block elevator against to movement and trim tab control lever set to the neutral position. Apply a load of 20 N (preferably according to a dynamometer) to the trim tab trailing edge. The trim tab deflection musn't exceed value of 5^{+2} mm from the original position. If the trim tab deflection exceeds this value, then it is necessary to adjust trim tab cable preload by adjusting screws.



3.5 Permissible Tolerances

Type of maintenance: clearance finding - line.
play compensation - heavy

Authorization to perform:

clearance finding - Aircraft owner (only for ELSA)
- Sport pilot or higher

play compensation – Repairman (LS-M) or Mechanic (A&P) – both with the minimum level of certification to perform heavy maintenance of SLSA in the U.S.
– FAA approved Part 145 Repair station

Tools needed: no special tools to find excessive play

Parts needed: swivel bearing, pins if replacement is necessary to be consulted with aircraft manufacturer.

The following table indicates the permissible tolerances for critical parts of the airplane. These values should not be exceeded in operation.

It is expected that an operator will take steps if excessive plays are found on/in part not listed below.

System	Procedure to find a play	Procedure to remedy a play	Max. product. play	Max. operat. play
Ailerons control system	Block ailerons up to the wing and move the control stick to the left and right	Check condition of bearings and replace if needed	0.08 in 2 mm	0.2 in 5 mm
Elevator control system	Block elevator up to the stabilizer, pull and push the control	Check condition of bearings and replace if needed	0.08 in 2 mm	0.2 in 5 mm
Flaps control system	Set the flaps in all position by degrees and then handle the flap trailing edge near the flap root, move the trailing edge up/downward to find possible plays	Check the part with oval hole for the control pin in the flap root rib and replace the worn-out pin or the part with oval hole.	0.08 in 2 mm	0.2 in 5 mm
Trim tab control system	Block the tab up to the elevator, move the trim tab control lever to find a play in a control system	Check cable tension	0.08 in 2 mm	0.2 in 5 mm
Wing-Fuselage attachment	Move the wing tip and note play in wing suspensions (play is measured on the wing tip).	Check wing suspensions, replace pins	0.08 in 2 mm	0.16 in 4 mm
HTU attachment	Move the stabilizer tip forward-rearward	Replace bearings in suspension points and bearings in control system	0	0.08 in 2 mm
Rudder hinges	Lift the rudder	Change swivel bearing or insert a washer under the lower hinge pin	0.04 in 1 mm	0.08 in 2 mm
Nose wheel	Push the rear part of the fuselage down (use a weight) to lift the nosewheel, then move the wheel forward- rearward	Remove the wheel, remove the rim and tire and replace the bearings	0.04 in 1 mm	0.12 in 3 mm
Main landing gear	Lift the wing tip (hold the wing under the main spar) to lift a main leg, then move the wheel forward-rearward and note play in bearings or leg attachment	Check the leg attachment, wheels attachment, replace the bearings, if necessary	0.04 in 1 mm	0.12 in 3 mm

Task proper accomplishment check: check replaced parts are properly installed, check plays after replacement



3.6 Weighing the airplane and C.G. calculation

WARNING

Never exceed the maximum takeoff weight and c.g. range for any configuration of crew, fuel and baggage as shown in the Aircraft Operating Instructions.

The removal or addition of equipment may result in changes to the center of gravity and empty weight of the aircraft. The permissible useful load can also be affected. In such case a new weight and balance is necessary to determine the new empty weight and center-of-gravity position. The new empty weight and C.G. position should be recorded in the Aircraft Operating Instructions, Section 6., Weight and Balance Record / Permitted Payload Range. Then a new permitted crew weight for fueling and baggage must be computed and recorded. The cockpit placard "Load Limits" should also be up-dated.

3.6.1 Empty weight determination

Type of maintenance: line.

Authorization to perform: - Aircraft owner (only for ELSA)
- Sport pilot or higher

Tools needed:

- scales
- ramp boards
- rests under wheels to level the aircraft

Parts needed: Weight and Balance Record

Instructions:

The empty weight of an aircraft includes all operating equipment that has a fixed location and is actually installed in the airplane. It includes the weight of the painted airplane, accumulator, standard and optional equipment, full engine coolant, hydraulic fluid, brake fluid, oil and unusable fuel (2.0 liters / 0.5 USGal). The aircraft is weighed without crew and baggage.

The following weighing procedure is recommended:

1. Remove excessive dirt, grease, moisture from the airplane before weighing
2. Weigh the airplane inside a closed building to prevent errors due to wind
3. Place the scales, calibrate zero
4. Place the airplane on the scales (use boards to run on the scales or lift the airplane - see airplane jacking)
5. Place the airplane in a level flight position (use suitable rests under the wheels)
6. Check the configuration for weighing (e.g. empty weight);
7. Weigh the airplane and record the values in Weight and Balance Record (make a copy of standard Record included in section 6 Appendices).
8. Compute the weight and C.G. position according to the formula Weight and Balance Record
9. Compute and record permitted crew weight for fueling and baggage - see Aircraft Operating Instructions par. 6.3.
10. Up-date the placard "Load Limits" (make a new one) and attach in the cockpit.

Task proper accomplishment check: push a wing down to rock the aircraft and then repeat weighing. You should get the same results like before.



3.6.2 Operating C.G. Range calculation

On the basis of knowledge of arms, weights of items, airplane empty weight and the C.G. position it is possible to calculate weight and C.G. position according to below given formula:

Loading Schedule Chart							
Your Aircraft			Sample Aircraft			Your Aircraft	
No	Item	Arm * (in)	Arm (in)	Weight (lb)	Moment/100 (lb-in)	Weight (lb)	Moment/100 (lb-in)
1.	Empty Airplane		10,39 in	740,75 lb	77,1 lb-in		
2.	Crew	21,45 in		399,04 lb	85,6 lb-in		
3.	Baggage (Max. 55 lb)	42,65 in		11,02 lb	4,7 lb-in		
4.	Fuel (Max. 32 USGAL)	26,75 in		60,41 lb	16,2 lb-in		
5.	Total weight (Takeoff weight) = Sum of weights 1-4 (MTOW 1320 lb) Total moment = Sum of moments 1-4			1211 lb	184 lb-in		

*) – for your empty airplane arm see Weight and Balance Record delivered with your airplane

C.G. position from Datum (Leading edge):

$$C.G. = \frac{\text{Total Moment}}{\text{Total Weight}} = \frac{\dots\dots\dots}{\dots\dots\dots} = \dots\dots\dots [in] \text{ or } [mm]$$

C.G. position in % MAC

(MAC ...Mean Aerodynamic Chord = 49.2 in i.e.1250 mm):

$$C.G. = \frac{C.G.}{MAC} \cdot 100 = \frac{\dots\dots\dots}{\dots\dots\dots} \cdot 100 = \dots\dots\dots [\% \text{ MAC}]$$

C.G. range limits

Empty weight C.G. range (standard equipment)..... 20 ± 2 % MAC
 Operating C.G. range..... 20 ÷ 34 % MAC



3.7 Ground handling

All ground handling activities described below are considered as Line Maintenance and may be performed by Sport Pilot or higher (or Aircraft owner for ELSA).

3.7.1 Towing the airplane

It is easy to tow the airplane a short distance by holding the blade root, since the empty weight of this airplane is relatively low.

Suitable surfaces to hold the aircraft airframe, are the rear part of the fuselage before the fin and the wing roots.

A tow bar may be used to tow the aircraft over long distances. Steerable nose wheel is equipped with the stops, it is impossible to turn it around.

3.7.2 Parking the airplane

It is advisable to park the aircraft inside a hangar, or eventually inside a other weather proof space (such as a garage) with stable temperature, good ventilation, low humidity and a dust-free environment.

It is necessary to tie-down the aircraft when parking outside.

On occasions when the plane must be tied-down outdoors for extended periods, it is advisable to cover the cockpit canopy, and if possible, the entire aircraft using a suitable cover.

The space requirements in the case of long-term hangaring may be reduced by removing or folding the wings. We recommend removing the battery in winter and storing it at indoor temperature.

CAUTION

Avoid parking airplane (especially airplane with dark design) on the direct sunshine during warm climate - then "can effect" or wave can arise on the upper skin of the wing and fuselage. It disappear when airplane is parked in the hangar, in the shadow or during taxiing or in flight when airplane surface is cooled with air flow.

This "can effect" or wave arised during parking has no effect onto functionality and it cannot be subject of claim.

3.7.3 Tieing-Down

The airplane is usually tied-down when parked outside a hangar. The tie-down is necessary to protect the aircraft against possible damage caused by wind gusts.

For this reason the aircraft is equipped with tie-down eyes, located on the wing lower surface.

Procedure:

1. Check: Fuel valve off, Circuit breakers and Master switch off, Switch box off.
2. Block the control stick up e.g. by means of safety harness or connect the control stick with rudder pedals by means of a suitable rope.
3. Shut all the ventilation windows
4. Close and lock cockpit
5. Tie-down the aircraft to the ground by means of a mooring rope passed through the eyes, located on the wing lower surface. It is also necessary to tie the nose wheel landing gear and the tail skid to the ground.

NOTE

It is advisable to cover cockpit canopy, if possible the whole airplane, by means of a suitable covering material attached to the airframe for long term outside parking..



3.7.4 *Jacking the airplane*

Because the empty weight of this airplane is relatively low it is easy to lift the airplane using 2 people.

First prepare two suitable jacks or supports to support the aircraft. Aircraft fuselage can be supported on the places marked by the black triangles in the figure below.

The aircraft should be lifted by the following parts:

- Press-down on the rear of the fuselage in front of the fin to lift the front and then support under the firewall.
- To jack the rear of the fuselage, grab the fuselage near the auxiliary tail skid, lift it upward and then support.
- To lift the wings, push on the wings lower surface at the main spar. Do not lift by the wing tips.

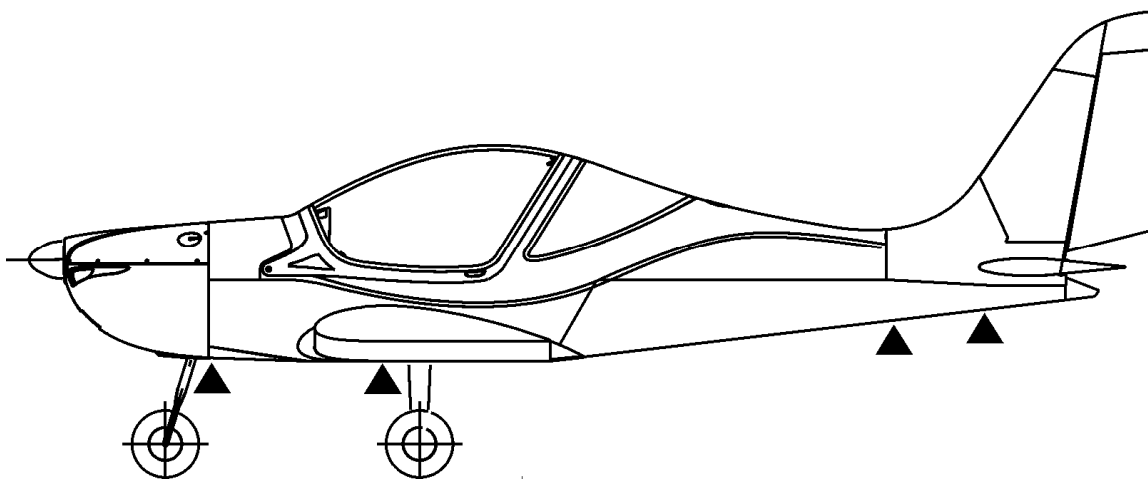

3.8 Road transport

The aircraft may be transported in a suitable trailer. It is necessary to remove the wings before loading. The aircraft and removed wings should be fastened down securely to ensure against possible damage.



Intentionally left blank



4. MAINTENANCE



4.1 Overall maintenance survey

Airplane maintenance is required to maintain its airworthiness. Periodical events are performed (periodical and pre-flight inspections) along with irregular events e.g. a repair of a damage as required.

The owner/operator of an LSA airplane shall be responsible for notifying the manufacturer of any safety of flight issue or significant service difficulty upon discovery.

The latest safety of flight information developed by the manufacturer are available on the manufacturer web site <http://www.evektor.cz> (mandatory bulletins) or by post on request. Contact the manufacturer if in doubt.

Contact address:

Evektor-Aerotechnik a.s.
Letecká 1384
686 04 Kunovice
Czech Republic

tel.: +420 572 537 111
fax: +420 572 537 900
e-mail: marketing@evektor.cz

Owner/Operator Responsibilities:

- Each owner/operator of an LSA airplane shall read and comply with the maintenance and continued airworthiness information and instructions provided by the manufacturer.
- Each owner/operator of an LSA airplane shall be responsible for providing the manufacturer with current contact information where the manufacturer may send the owner/operator Supplemental notification bulletins.
- The owner/operator of an LSA airplane shall be responsible for notifying the manufacturer of any safety of flight issue or significant service difficulty upon discovery.
- The owner/operator of an LSA airplane shall be responsible for complying with all manufacturer issued notices of corrective action and for complying with all applicable aviation authority regulations in regard to maintaining the airworthiness of the LSA airplane.
- An owner of an LSA airplane shall ensure that any needed corrective action must be completed as specified in a notice, or by the next scheduled annual inspection.
- Should an owner/operator not comply with any mandatory service requirement, the LSA airplane shall be considered not in compliance with applicable ASTM Standards and may be subject to regulatory action by the presiding aviation authority.

4.1.1 Terminology

A&P: A US FAA certificated Mechanic as defined by 14 CFR Part 65.

LSA Repairman Inspection: A US FAA certificated repairman (light-sport aircraft) with and inspection rating as defined by 14 CFR part 65, authorized to perform the annual condition inspection on experimental light-sport aircraft, which the repairman owns. ¹Note: Experimental LSA do not require the individual performing maintenance to hold any FAA airman certificate.

LSA Repairman Maintenance: A US FAA certificated repairman (light-sport aircraft) with a maintenance rating as defined by 14 CFR part 65, authorized to perform line maintenance on aircraft certificated as special LSA aircraft. Authorized to perform the annual condition/100 inspection on special and experimental light-sport aircraft,

LSA Aircraft (Light Sport Aircraft) - An aircraft designed per ASTM F2245 (airplanes) and complies with the U.S. Code of Federal Regulations Chapter 14 Part 1 definition for a light sport aircraft and will be certificated in the US as SLSA or ELSA.

FAA: United States Federal Aviation Administration



14 CFR: Code of federal regulations chapter 14 Aeronautics and Space also know as the "FARs" or federal aviation regulations.

Manufacturer – Any entity engaged in the production of a SLSA or ELSA or component used on an LSA.

Maintenance Manual(s) – A manual provided by a SLSA or ELSA manufacturer (this manual) or supplier that specifies all maintenance, repairs and alterations authorized by the manufacturer.

Line Maintenance – Any unscheduled maintenance resulting from unforeseen events, or scheduled checks that contain servicing and/or inspections not considered heavy maintenance that is approved by the manufacturer and is specified in the manufacturer’s maintenance manual.

Authorization to perform: The holder of a LSA Repairman certificate, with either an inspection or maintenance rating is generally considered the minimum level of certification to perform line maintenance of LSA in the U.S..

Note: Many of the tasks listed are also authorized, by the FAA, to be performed by the owner of the SLSA which holds a sport pilot certificate. The examples listed below should not be considered as restrictions against the performance of the tasks by an owner that is authorized to perform said task by the FAA.

Typical tasks considered as line maintenance for LSA 's include:

1. 100 hour inspection
2. Annual Condition Inspection
3. Servicing of fluids
4. Removal and replacement of components for which instructions are provided in the maintenance manual such as:
 - Fuel pumps
 - Batteries
 - Instruments, switches, lights and circuit breakers
 - Starters/generators/alternators
 - Exhaust manifolds/mufflers
 - Wheel and brake assemblies
 - Propellers
 - Sparkplugs, ignition wires and electronic ignition models/components limited to the use of mechanical connections
 - Hoses and lines
 - Sailcloth covering
 - Ballistic Recovery System
5. Repair of components and structure for which instructions are provided in the maintenance manual and which do not require additional specialized training such as:
 - Patching of a hole in a fabric, metal or composite non-structural component.
 - Stop-drilling of cracks
6. Alterations for which specific instruction are provided in the maintenance manual such as:
 - Installation of a communications radio, GPS and antenna
 - Installation of a strobe light system
 - Compliance with a manufacturer service directive when the repairman is listed as an authorized person to accomplish the alteration.

Heavy Maintenance – Any maintenance, inspection, repair or alteration that requires specialized training, equipment, or facilities.

Authorization to perform: The holder of an FAA Mechanic certificate with Airframe and or Powerplant rating(s); or a LSA Repairman maintenance that has received additional task specific training for the function to 'be performed is generally considered the minimum level of certification to perform heavy maintenance of SLSA in the U.S..

<p>Document No.: SSM2008MAIPUS</p>	<p>Date of Issue: March 01, 2009</p>	<p>Revision: -</p>	<p>4-3</p>
--	--	-------------------------------	-------------------



Typical tasks considered as heavy maintenance for SLSA 's include:

1. Removal and replacement of components for which instructions are provided in the maintenance manual or service directive instructions such as:
 - Complete engine removal and reinstallation in support of an engine overhaul or to install a new engine.
 - Remove and replacement of engine cylinders, pistons, and or valve assemblies
 - Primary flight control cables/components
 - Landing gear assemblies
2. Repair of components and or aircraft structure for which instructions are provided in the maintenance manual or service directive instructions such as:
 - Repainting of control surfaces
 - Structural repairs
 - Recovering of a dope and fabric covered aircraft
3. Alterations of components and or aircraft structure which instruction are provided in the maintenance manual or service directive instruction such as:
 - Installation of skis
 - Installation of new additional pitot static instruments

Overhaul – Maintenance, inspection, repair or alterations that are only to be accomplished by the original manufacturer or a facility approved by the original manufacture of the product.

Authorization to perform: Only the manufacturer of a SLSA or the component to be overhauled on a SLSA may perform or authorize to be performed the overhaul of a SLSA or SLSA component. No FAA certification is given to be a SLSA approved overhaul facility.

Overhaul manual: A separate overhaul manual, not the manufacturers maintenance manual, is required to perform the overhaul of a SLSA or SLSA component. The form and content of such a manual is not governed by this standard or by any FAA regulation. Note: Specific form and content guidelines have not been promulgated here as type specific training and authorization is required from the manufacturer in order to overhaul a SLSA or component.

Typical components that are overhauled include:

- Engines
- Carburetors/fuel injection systems
- Starters/alternators/generators
- Instruments

Overhaul Facility – A facility specifically authorized by the aircraft or component manufacturer to overhaul the product originally produced by that manufacturer.

Annual Condition Inspection – A detailed inspection accomplished once a year on a SLSA or ELSA in accordance with instructions provided in the maintenance manual (refer to 4.4.1. [Periodical inspection intervals](#)) supplied with the aircraft. The purpose of the inspection is to look for any wear, corrosion, or damage that would cause an aircraft to not be in a condition for safe operation.

100 Hour Inspection – Same as an annual condition inspection except the interval of inspection is 100 hours of operation instead of 12 calendar months. This inspection is utilized when the SLSA or ELSA is being used for commercial operations such as flight instruction and or rental.



4.1.2 Qualification requirements

Maintenance and Repairs of LSA

The factory-built SportStar MAX belongs to Special-Light Sport Aircraft category, while the SportStar MAX built from a kit to Experimental-Light Sport Aircraft category. This fact determines the conditions for aircraft maintenance and repairs, as explained hereafter:

Special-Light Sport Aircraft

A special LSA is a factory-built, ready-to-fly aircraft. They must be maintained and inspected by a certificated repairman with a LSA maintenance rating, an A&P, or an FAA authorized repair station. Pilots can perform preventive maintenance on S-LSA.

Experimental-Light Sport Aircraft (New Kit-Built)

The builder must perform all maintenance in accordance with the manufacturer maintenance manuals.

Builders can perform the annual condition inspection if they hold an FAA repairman certificate-inspection, otherwise an A&P or FAA authorized repair station must perform the inspection.

Earning a Repairman Certificate-Base Requirements

To earn an FAA repairman certificate of any type, you must be:

- 18 years old
- Speak, read, and understand English
- Demonstrate the requisite skill to determine whether a LSA is in a condition for safe operation
- U.S. citizen or legal permanent resident

Repairman Certificate—Inspection

In addition to meeting the base requirements, to earn an FAA repairman certificate-inspection you must complete an FAA-approved 16-hour training course on inspecting light sport aircraft. This certificate enables you to perform the annual condition inspection on the Experimental-LSA you own.

Repairman Certificate-Maintenance

In addition to meeting the base requirements, to earn an FAA repairman certificate-maintenance you must complete an FAA-approved 80- to 120-hour training course on inspecting and maintaining light sport aircraft (time depends on LSA type). This certificate allows you to maintain, repair, and perform the annual condition inspection on all Special - LSAs and condition inspections on Experimental - LSAs. What repairs and maintenance you can perform are specifically authorized in the aircraft manufacturer's maintenance manual. A&Ps or FAA authorized repair stations must perform all major modifications.

<p>Document No.: SSM2008MAIPUS</p>	<p>Date of Issue: March 01, 2009</p>	<p>Revision: -</p>	<p>4-5</p>
--	--	-------------------------------	-------------------



Review of the required ground staff qualification for maintenance and inspections:

	SportStar MAX built from a kit (ELSA under §21.191 (i) 1,320 pounds MTOW)	Factory-built SportStar MAX (SLSA under §21.190 1,320 pounds MTOW)
Maintenance	Owner- maintained	Maintenance-- <ul style="list-style-type: none"> • Repairman (LS-M) • Mechanic (A&P) • Part 145 Repair station Preventive maintenance Sport pilot or higher
Inspections	Annual condition <ul style="list-style-type: none"> • Repairman LS –I and LS-M • Mechanic (A & P) • Part 145 Repair station 100-hour condition <ul style="list-style-type: none"> • Repairman LS-M • Mechanic (A & P) • Part 145 Repair station 	Annual condition <ul style="list-style-type: none"> • Repairman LS - M • Mechanic (A & P) • Part 145 Repair station 100-hour condition <ul style="list-style-type: none"> • Repairman LS-M • Mechanic (A & P) • Part 145 Repair station

REVIEW MAINTENANCE TYPE VERSUS REQUIRED QUALIFICATION

LINE MAINTENANCE	HEAVY MAINTENANCE	OVERHAUL
Authorization to perform: <ul style="list-style-type: none"> • Aircraft owner (only for ELSA) • Sport pilot or higher • Repairman (LS-M) • Mechanic (A&P) • Part 145 Repair station 	Authorization to perform: <ul style="list-style-type: none"> • Repairman (LS-M) or Mechanic (A&P) – both with the minimum level of certification to perform heavy maintenance of SLSA in the U.S.. • FAA approved Part 145 Repair station 	Authorization to perform: <ul style="list-style-type: none"> • manufacturer of a SLSA / ELSA or the component • facility specifically authorized by the aircraft or component manufacturer
Typical tasks: <ol style="list-style-type: none"> 1. 100 hour inspection 2. Annual Condition Inspection 3. Servicing of fluids 4. Removal and replacement of components for which instructions are provided in the maintenance manual such as: <ul style="list-style-type: none"> • Fuel pumps • Batteries • Instruments, switches, lights and circuit breakers • Starters /generators /alternators • Exhaust manifolds/mufflers • Wheel and brake assemblies • Propellers • Sparkplugs, ignition wires and electronic ignition models/components limited to the use of mechanical 	Typical tasks: <ol style="list-style-type: none"> 1. Removal and replacement of components for which instructions are provided in the maintenance manual or service directive instructions such as: <ul style="list-style-type: none"> • Complete engine removal and reinstallation in support of an engine overhaul or to install a new engine. • Remove and replacement of engine cylinders, pistons, and or valve assemblies • Primary flight control cables/components • Landing gear assemblies 2. Repair of components and or aircraft structure for which instructions are provided in the maintenance manual or service directive instructions such as: 	Typical tasks: <p>Overhaul of the:</p> <ul style="list-style-type: none"> • Engines • Carburetors/fuel injection systems • Starters/alternators/generators • Instruments



LINE MAINTENANCE	HEAVY MAINTENANCE	OVERHAUL
<p>connections</p> <ul style="list-style-type: none"> • Hoses and lines • Sailcloth covering • Ballistic Recovery System <p>5. Repair of components and structure for which instructions are provided in the maintenance manual and which do not require additional specialized training such as:</p> <ul style="list-style-type: none"> • Patching of a hole in a fabric, metal or composite non-structural component. • Stop-drilling of cracks <p>6. Alterations for which specific instruction are provided in the maintenance manual such as:</p> <ul style="list-style-type: none"> • Installation of a communications radio, GPS and antenna • Installation of a strobe light system • Compliance with a manufacturer service directive when the repairman is listed as an authorized person to accomplish the alteration. 	<ul style="list-style-type: none"> • Repainting of control surfaces • Structural repairs • Recovering of a dope and fabric covered aircraft <p>3. Alterations of components and or aircraft structure which instruction are provided in the maintenance manual or service directive instruction such as:</p> <ul style="list-style-type: none"> • Installation of skis • Installation of new additional pitot static instruments 	
<p>Refer to particular maintenance action for authorized person to perform maintenance.</p>		

4.2 Pre-flight inspection

Type of maintenance: line.

Authorization to perform:

- Aircraft owner (only for ELSA)
- Sport pilot or higher

Tools needed: flat screwdriver to remove upper engine cowling

Parts needed: none

Instructions: refer to Aircraft Operating Instructions section 4, item 4.4.4.

A pre-flight inspection is performed prior to the beginning of each flight. A pre-flight inspection should be repeated prior to each flight even during the same day.

The Pre-flight inspection is a visual check of the aircraft for deformations, surface damage, fuel and oil system leaks, prop damage, released locks, covers and cowlings etc.

Any damage or failure should be repaired immediately if the airworthiness is affected or when the aircraft can not be put out of operation.

It is important to perform a pre-flight inspection carefully to prevent problems from arising.

Refer to the Aircraft Operating Instructions for more details.

<p>Document No.: SSM2008MAIPUS</p>	<p>Date of Issue: March 01, 2009</p>	<p>Revision: -</p>	<p>4-7</p>
--	--	-------------------------------	-------------------



4.3 Post-flight inspection

Type of maintenance: line.

Authorization to perform:

- Aircraft owner (only for ELSA)
- Sport pilot or higher

Tools needed: flat screwdriver to remove upper engine cowling

Parts needed: none

Instructions: refer to Aircraft Operating Instructions section 4, item 4.4.4.

Post-flight inspection is performed at the end of each flight day; the post-flight inspection events are the same as the preflight ones. If possible failures, damages and malfunctions should be recorded and repaired immediately. It is recommended to clean and/or wash the airplane and check that the fuel and oil consumption are in the normal range.

Lastly record all hours flown and other data in appropriate documentation (Log Book etc.).

4.4 Periodical inspections

4.4.1 Periodical inspection intervals

Type of maintenance: line.

Authorization to perform:

- Aircraft owner (only for ELSA)
- Sport pilot or higher

Tools needed: set of basic metric tools, no specials tools required.

Parts needed: Refer to 4.4.3.

Instructions: Refer to 4.4.3.

Task proper accomplishment check: Refer to 4.4.3.

The periods for overall checks and contingent maintenance will depend on the conditions of the operation and the overall condition of the airplane. The manufacturer recommends maintenance checks and periodic inspections in the following periods:

- 1) after the first 25 ± 2 flight hours
 - 2) after every 50 ± 3 flight hours
- after every 100 ± 5 hours of service or 1 times per two years as minimum
airplanes older than 8 years or having more than 3000 flight hours once a year.

Refer to the Rotax 912 Operator's Manual for engine maintenance.

Refer to the Propeller Maintenance Manual for propeller maintenance.

4.4.2 Periodical inspection actions

The following Periodical Inspection Checklists are intended for copying and serve as the Maintenance Records. It is also recommended to include small repairs, damages and their remedy or replacement.

Some parts of the airplane (engine, propeller etc.) may have special time limits - refer to the appropriate manuals for maintenance time limits and procedures.



4.4.3 Periodical Inspections Checklists

Model: SportStar MAX	S/N.:	Hours flown:	Date of inspection:
	Registration:	No. of Takeoffs:	

Event #	Event description	Inspection				Carried out by:	Inspected by:
		<input checked="" type="checkbox"/> Tick off performed inspection					
		after the first 25 hrs.	after the first 50 hrs.	every 50 hrs.	every 100 hrs.		
1.	Prior to the inspection clean and wash the airplane surfaces, if needed.	<input checked="" type="checkbox"/>	<input checked="" type="checkbox"/>	<input checked="" type="checkbox"/>	<input checked="" type="checkbox"/>		
2.	ENGINE	see engine manufacturer's instructions					
3.	ENGINE COMPARTMENT						
3.1.	Fiberglass engine cowlings						
3.1.1.	Check condition of cowlings and quick closing locks - repair any damage				<input checked="" type="checkbox"/>		
3.1.2.	Remove engine cowling	<input checked="" type="checkbox"/>	<input checked="" type="checkbox"/>		<input checked="" type="checkbox"/>		
3.1.3.	Visually check inside fireproof primer paint - Repaint if needed - White color T 50, Norm V1000 N 56582, thermal protection		<input checked="" type="checkbox"/>		<input checked="" type="checkbox"/>		
3.2.	Engine mount						
3.2.1.	Visually check condition, attachment, security of attachment bolts: engine-engine mounting, engine mounting-firewall	<input checked="" type="checkbox"/>	<input checked="" type="checkbox"/>		<input checked="" type="checkbox"/>		
3.2.2.	Visually check condition of rubber silentblocks - replace those cracked and excessively deformed				<input checked="" type="checkbox"/>		
3.3.	Suction system						
3.3.1.	Visually check condition, attachment and security of air filter at carburetor inlet - clean filter acc. to the engine manual	<input checked="" type="checkbox"/>	<input checked="" type="checkbox"/>		<input checked="" type="checkbox"/>		
3.3.2.	Visually check condition of suction tubing	<input checked="" type="checkbox"/>	<input checked="" type="checkbox"/>		<input checked="" type="checkbox"/>		
3.3.3.	Check carburetor - condition, control cables attachment, lubricate cables at inlet to the bowdens, thermal protection	<input checked="" type="checkbox"/>	<input checked="" type="checkbox"/>		<input checked="" type="checkbox"/>		
3.4.	Battery						
3.4.1.	Visually check attachment and security		<input checked="" type="checkbox"/>		<input checked="" type="checkbox"/>		
3.4.2.	Check charging - charge if needed				<input checked="" type="checkbox"/>		
3.4.3.	Visually check condition and attachment of wire leads - replace those damaged	<input checked="" type="checkbox"/>	<input checked="" type="checkbox"/>		<input checked="" type="checkbox"/>		
3.4.4.	Load test				<input checked="" type="checkbox"/>		
3.5.	Wiring						
3.5.1.	Visually check condition and integrity of wires, connections, security of wires and grounding	<input checked="" type="checkbox"/>	<input checked="" type="checkbox"/>		<input checked="" type="checkbox"/>		
3.6.	Fuel system						
3.6.1.	Visually check condition, integrity, attachment and security of hoses - replace those damaged	<input checked="" type="checkbox"/>	<input checked="" type="checkbox"/>		<input checked="" type="checkbox"/>		
3.6.2.	Visually check fuel filter condition - replace stopped up filter	<input checked="" type="checkbox"/>	<input checked="" type="checkbox"/>		<input checked="" type="checkbox"/>		
3.6.3.	Visually check system for leaks	<input checked="" type="checkbox"/>		<input checked="" type="checkbox"/>	<input checked="" type="checkbox"/>		

Document No.: SSM2008MAIPUS	Date of Issue: March 01, 2009	Revision: -	4-9
--	--	-----------------------	------------



Event #	Event description	Inspection <input checked="" type="checkbox"/> Tick off performed inspection				Carried out by:	Inspected by:	
		after the first 25 hrs.	after the first 50 hrs.	every 50 hrs.	every 100 hrs.			
3.7.	Cooling system							
3.7.1.	Visually check radiator for condition and leaks				<input checked="" type="checkbox"/>			
3.7.2.	Visually check condition, attachment of hoses; radiator left hose clearance from exhaust pipe approx. 0.8 in (20 mm), check system for leaks	<input checked="" type="checkbox"/>	<input checked="" type="checkbox"/>	<input checked="" type="checkbox"/>	<input checked="" type="checkbox"/>			
3.7.3.	Tighten hose clips if needed		<input checked="" type="checkbox"/>		<input checked="" type="checkbox"/>			
3.7.4.	Check coolant quantity in the expansion tank - add or change coolant acc. to the engine manual if needed	<input checked="" type="checkbox"/>	<input checked="" type="checkbox"/>	<input checked="" type="checkbox"/>	<input checked="" type="checkbox"/>			
3.7.5.	Visually check condition and attachment of overflow bottle on the firewall				<input checked="" type="checkbox"/>			
3.8.	Lubrication system							
3.8.1.	Visually check condition and attachment of oil tank				<input checked="" type="checkbox"/>			
3.8.2.	Check oil cooler for condition, attachment and leaks	<input checked="" type="checkbox"/>	<input checked="" type="checkbox"/>	<input checked="" type="checkbox"/>	<input checked="" type="checkbox"/>			
3.8.3.	Visually check hoses for condition, leaks, attachment and security - replace damaged hoses	<input checked="" type="checkbox"/>	<input checked="" type="checkbox"/>		<input checked="" type="checkbox"/>			
3.8.4.	Check oil quantity - add or change oil acc. to the engine manual if needed	<input checked="" type="checkbox"/>	<input checked="" type="checkbox"/>	<input checked="" type="checkbox"/>	<input checked="" type="checkbox"/>			
3.9.	Exhaust system							
3.9.1.	Visually check exhaust system for condition, cracks, deformations or damage - repair / replace. Check left front pipe clearance from radiator hose - approx. 0.8 in (20 mm),	<input checked="" type="checkbox"/>	<input checked="" type="checkbox"/>	<input checked="" type="checkbox"/>	<input checked="" type="checkbox"/>			
3.9.2.	Visually check condition and attachment of the muffler - repair / replace	<input checked="" type="checkbox"/>	<input checked="" type="checkbox"/>	<input checked="" type="checkbox"/>	<input checked="" type="checkbox"/>			
3.9.3.	Check joint security	<input checked="" type="checkbox"/>	<input checked="" type="checkbox"/>	<input checked="" type="checkbox"/>	<input checked="" type="checkbox"/>			
3.10.	Heating							
3.10.1.	Visually check hoses leading air into the cockpit - check hose for condition, integrity, attachment and security		<input checked="" type="checkbox"/>		<input checked="" type="checkbox"/>			
3.10.2.	Check condition, function and control of the heating / venting system flaps		<input checked="" type="checkbox"/>		<input checked="" type="checkbox"/>			
3.11.	Reinstall lower engine cowling Reinstall lower engine cowling when the inspection is completed and engine test run performed	<input checked="" type="checkbox"/>	<input checked="" type="checkbox"/>	<input checked="" type="checkbox"/>	<input checked="" type="checkbox"/>			
3.12.	Lubricate per Lubricating Chart	<input checked="" type="checkbox"/>	<input checked="" type="checkbox"/>		<input checked="" type="checkbox"/>			
4.	PROPELLER	see manufacturer instructions +						
4.1.	Blades							
4.1.1.	Inspect blades for abrasions, cracks, paint damage, condition of blades leading edges and tips - repair according to the propeller manual	<input checked="" type="checkbox"/>	<input checked="" type="checkbox"/>	<input checked="" type="checkbox"/>	<input checked="" type="checkbox"/>			
4.2.	Spinner							
4.2.1.	Visually check spinner for condition, abrasions, cracks, paint damage - repair large damage		<input checked="" type="checkbox"/>	<input checked="" type="checkbox"/>	<input checked="" type="checkbox"/>			
4.2.2.	Remove spinner		<input checked="" type="checkbox"/>	<input checked="" type="checkbox"/>	<input checked="" type="checkbox"/>			



Event #	Event description	Inspection				Carried out by:	Inspected by:
		<input checked="" type="checkbox"/> Tick off performed inspection					
		after the first 25 hrs.	after the first 50 hrs.	every 50 hrs.	every 100 hrs.		
4.3.	Propeller	see manufacturer instructions +					
4.3.1.	Check prop attachment, security of bolts		<input checked="" type="checkbox"/>		<input checked="" type="checkbox"/>		
4.3.2.	Check run-out				<input checked="" type="checkbox"/>		
4.3.3.	Install spinner		<input checked="" type="checkbox"/>	<input checked="" type="checkbox"/>	<input checked="" type="checkbox"/>		
4.3.4.	Check tightening by torque wrench				<input checked="" type="checkbox"/>		
4.3.5.	Pitch change mechanism (if controllable pitch prop is mounted) Check condition and function according to the prop manufacturer's instructions	see manufacturer instructions					
5.	LANDING GEAR NOSEWHEEL LANDING GEAR						
5.1.	Nosewheel leg						
5.1.1.	Check condition and attachment of the nosewheel leg (lift airplane nose)	<input checked="" type="checkbox"/>	<input checked="" type="checkbox"/>	<input checked="" type="checkbox"/>	<input checked="" type="checkbox"/>		
5.2.	Wheel pants						
5.2.1.	Visually check wheel pants or mudguards condition - repair damages and cracks		<input checked="" type="checkbox"/>		<input checked="" type="checkbox"/>		
5.2.2.	Remove fairing (reinstall when nosewheel inspection is completed)				<input checked="" type="checkbox"/>		
5.3.	Rubber rope and rubber suspension stop						
5.3.1.	Visually check rubber rope a suspension stop and flexible washer for deformation, cracks, excessive wear - replace if needed		<input checked="" type="checkbox"/>		<input checked="" type="checkbox"/>		
5.4.	Tire						
5.4.1.	Check tires for condition, cuts, uneven or excessive wear and slippage - replace if needed		<input checked="" type="checkbox"/>		<input checked="" type="checkbox"/>		
5.4.2.	Check pressure - inflate to required pressure	<input checked="" type="checkbox"/>	<input checked="" type="checkbox"/>	<input checked="" type="checkbox"/>	<input checked="" type="checkbox"/>		
5.5.	Wheel						
5.5.1.	Visually check for cracks, permanent deformations - if damaged, replace				<input checked="" type="checkbox"/>		
5.5.2.	Check valve condition around the hole in the rim				<input checked="" type="checkbox"/>		
5.5.3.	Check condition of bearings, wheel free rotation, play				<input checked="" type="checkbox"/>		
5.6.	Joints						
5.6.1.	Check torque and security of fixed joints	<input checked="" type="checkbox"/>	<input checked="" type="checkbox"/>		<input checked="" type="checkbox"/>		
5.6.2.	Check nosewheel free rotation inside the leg - the rotation should not be too free to prevent shimmy		<input checked="" type="checkbox"/>		<input checked="" type="checkbox"/>		
5.7.	Nosewheel control system						
5.7.1.	Check control rods condition, rod ends security		<input checked="" type="checkbox"/>		<input checked="" type="checkbox"/>		
5.7.2.	Check condition of nosewheel control lever covers for wear through - repair damage				<input checked="" type="checkbox"/>		
5.8.	Lubricate per Lubricating Chart	<input checked="" type="checkbox"/>	<input checked="" type="checkbox"/>		<input checked="" type="checkbox"/>		
6.	LANDING GEAR MAIN LANDING GEAR						
6.1.	Fiberglass legs						
6.1.1.	Visually check condition of fiberglass legs - repaint damaged areas, contact airplane manufacturer if cracks were found	<input checked="" type="checkbox"/>	<input checked="" type="checkbox"/>	<input checked="" type="checkbox"/>	<input checked="" type="checkbox"/>		

Document No.: SSM2008MAIPUS	Date of Issue: March 01, 2009	Revision: -	4-11
--	--	-----------------------	-------------



Event #	Event description	Inspection <input checked="" type="checkbox"/> Tick off performed inspection				Carried out by:	Inspected by:
		after the first 25 hrs.	after the first 50 hrs.	every 50 hrs.	every 100 hrs.		
6.1.2.	Inspect leg attachment into the fuselage (no play) - Lift the landing gear and move a leg forward-backward, upward-downward; at the same time check wheel play on the axle - tighten attachment bolts if the leg has a play		<input checked="" type="checkbox"/>	<input checked="" type="checkbox"/>	<input checked="" type="checkbox"/>		
6.1.3.	Check torque and security of fixed joints	<input checked="" type="checkbox"/>	<input checked="" type="checkbox"/>		<input checked="" type="checkbox"/>		
6.1.4.	Check cloth cover which covers the leg-fuselage input hole				<input checked="" type="checkbox"/>		
6.1.5.	Check grounding				<input checked="" type="checkbox"/>		
6.2.	Wheel pants or mudguards						
6.2.1.	Visually check wheel pants / mudguards condition - repair damage and cracks		<input checked="" type="checkbox"/>		<input checked="" type="checkbox"/>		
6.3.	Tires						
6.3.1.	Check tires for condition, cuts, uneven or excessive wear and slippage - replace if needed	<input checked="" type="checkbox"/>	<input checked="" type="checkbox"/>		<input checked="" type="checkbox"/>		
6.4.	Wheel						
6.4.1.	Visually check wheel rims for cracks, permanent deformations - replace wheel rim in case of cracks				<input checked="" type="checkbox"/>		
6.4.2.	Check valve condition around the hole in the disc				<input checked="" type="checkbox"/>		
6.4.3.	Check condition of bearings, wheel free rotation, play		<input checked="" type="checkbox"/>		<input checked="" type="checkbox"/>		
6.5.	Brakes						
6.5.1.	Check attachment of brake system plastic hoses to the main leg				<input checked="" type="checkbox"/>		
6.5.2.	Visually check condition of pads - steady and symmetry abrasion of pads - replace pads if needed		<input checked="" type="checkbox"/>		<input checked="" type="checkbox"/>		
6.5.3.	Check wear of the disc and overheating				<input checked="" type="checkbox"/>		
6.5.4.	Check brake system for leaks - add brake fluid and bleed the system if a brake pedal has soft movement	<input checked="" type="checkbox"/>	<input checked="" type="checkbox"/>	<input checked="" type="checkbox"/>	<input checked="" type="checkbox"/>		
6.5.5.	By brake fluid replacement clean up and reseal brake cylinders – once two years						
7.	WING						
7.1.	Wing						
7.1.1.	Visually check condition - no loose rivets, deformations, cracks or any other damage - contact the airplane manufacturer	<input checked="" type="checkbox"/>	<input checked="" type="checkbox"/>		<input checked="" type="checkbox"/>		
7.1.2.	Check play of wing suspensions - move the wing tip upward-downward, frontward-rearward				<input checked="" type="checkbox"/>		
7.1.3.	Check condition and attachment of fiberglass wing tips				<input checked="" type="checkbox"/>		
7.1.4.	Visual check of riveted joints leakage of integral tank				<input checked="" type="checkbox"/>		
7.1.5.	Check desludging				<input checked="" type="checkbox"/>		
7.1.6.	Check wire integrity and grounding				<input checked="" type="checkbox"/>		
7.1.7.	Check labels				<input checked="" type="checkbox"/>		
7.2.	Aileron						



Event #	Event description	Inspection				Carried out by:	Inspected by:
		<input checked="" type="checkbox"/> Tick off performed inspection					
		after the first 25 hrs.	after the first 50 hrs.	every 50 hrs.	every 100 hrs.		
7.2.1.	Visually check condition	<input checked="" type="checkbox"/>	<input checked="" type="checkbox"/>		<input checked="" type="checkbox"/>		
7.2.2.	Check free movement	<input checked="" type="checkbox"/>	<input checked="" type="checkbox"/>		<input checked="" type="checkbox"/>		
7.2.3.	Check aileron hinge	<input checked="" type="checkbox"/>	<input checked="" type="checkbox"/>		<input checked="" type="checkbox"/>		
7.2.4.	Check play		<input checked="" type="checkbox"/>		<input checked="" type="checkbox"/>		
7.2.5.	Check security of control rod ends		<input checked="" type="checkbox"/>	<input checked="" type="checkbox"/>	<input checked="" type="checkbox"/>		
7.2.6.	Check grounding				<input checked="" type="checkbox"/>		
7.2.7.	Remove inspection covers from the lower wing surface to inspect security of control system joints		<input checked="" type="checkbox"/>		<input checked="" type="checkbox"/>		
7.2.8.	Lubricate per Lubricating Chart and reinstall covers and completed lever	<input checked="" type="checkbox"/>	<input checked="" type="checkbox"/>		<input checked="" type="checkbox"/>		
7.3.	Flap						
7.3.1.	Fully extend the flaps and visually check condition	<input checked="" type="checkbox"/>	<input checked="" type="checkbox"/>		<input checked="" type="checkbox"/>		
7.3.2.	Check flap hinge	<input checked="" type="checkbox"/>	<input checked="" type="checkbox"/>		<input checked="" type="checkbox"/>		
7.3.3.	Check play		<input checked="" type="checkbox"/>		<input checked="" type="checkbox"/>		
7.3.4.	Check condition of flap control pin and wear of the groove at the flap root				<input checked="" type="checkbox"/>		
7.3.5.	Lubricate per Lubricating Chart	<input checked="" type="checkbox"/>	<input checked="" type="checkbox"/>		<input checked="" type="checkbox"/>		
7.4.	Pitotstatic tube						
7.4.1.	Check pitotstatic tube attachment				<input checked="" type="checkbox"/>		
7.4.2.	Check pitostatic system for leaks - the airplane manufacturer uses KPU 3 instrument				<input checked="" type="checkbox"/>		
7.4.3.	Check hoses under pitotstatic tube (in bend)				<input checked="" type="checkbox"/>		
7.4.4.	Check fall sensor				<input checked="" type="checkbox"/>		
7.4.5.	Check safety system						
7.5.	Wing suspensions						
7.5.1.	Remove wing fillets	<input checked="" type="checkbox"/>	<input checked="" type="checkbox"/>		<input checked="" type="checkbox"/>		
7.5.2.	Visually check condition of wing suspensions (wing folding mechanism), cleanness of folding system, lubrication	<input checked="" type="checkbox"/>	<input checked="" type="checkbox"/>		<input checked="" type="checkbox"/>		
7.5.3.	Check wear, corrosion				<input checked="" type="checkbox"/>		
7.5.4.	Check security of joints	<input checked="" type="checkbox"/>	<input checked="" type="checkbox"/>		<input checked="" type="checkbox"/>		
7.6.	Lubricate per Lubricating Chart	<input checked="" type="checkbox"/>	<input checked="" type="checkbox"/>		<input checked="" type="checkbox"/>		
8.	FUSELAGE						
8.1.	Fuselage surface						
8.1.1.	Visually check condition - no loose rivets, deformations, cracks or any other damage, corrosion - repair small damage or contact the airplane manufacturer	<input checked="" type="checkbox"/>	<input checked="" type="checkbox"/>		<input checked="" type="checkbox"/>		
8.1.2.	Visually check rivets near the landing gear attachment				<input checked="" type="checkbox"/>		
8.1.3.	Check condition and attachment of equipment - antenna, beacon etc.				<input checked="" type="checkbox"/>		
8.1.4.	Check tail skid attachment				<input checked="" type="checkbox"/>		
8.1.5.	Visually check condition, attachment and operation of towing mechanism (if installed) and lubricate		<input checked="" type="checkbox"/>	<input checked="" type="checkbox"/>	<input checked="" type="checkbox"/>		
8.1.6.	Visually check condition of fiberglass wing fillets				<input checked="" type="checkbox"/>		
8.2.	Cockpit canopy						



Event #	Event description	Inspection				Carried out by:	Inspected by:
		☑ Tick off performed inspection					
		after the first 25 hrs.	after the first 50 hrs.	every 50 hrs.	every 100 hrs.		
8.2.1.	Visually check canopy condition for - cracks, scratches, any other damage - drill end of cracks	<input checked="" type="checkbox"/>	<input checked="" type="checkbox"/>		<input checked="" type="checkbox"/>		
8.2.2.	Check canopy lock for condition and operation, signalization	<input checked="" type="checkbox"/>	<input checked="" type="checkbox"/>		<input checked="" type="checkbox"/>		
8.2.3.	Check eye-ball vents for condition and operation				<input checked="" type="checkbox"/>		
8.2.4.	Check gas struts operation - replace those functionless				<input checked="" type="checkbox"/>		
8.2.5.	Check canopy silicone rubber packing				<input checked="" type="checkbox"/>		
8.2.6.	Check cabin lighting				<input checked="" type="checkbox"/>		
8.2.7.	Check cabin dewatering				<input checked="" type="checkbox"/>		
8.2.8.	Check labels				<input checked="" type="checkbox"/>		
9.	HORIZONTAL TAIL UNIT						
9.1.	Visually check condition - no loose rivets, deformation, cracks, scratches and any other damage - contact the airplane manufacturer	<input checked="" type="checkbox"/>	<input checked="" type="checkbox"/>		<input checked="" type="checkbox"/>		
9.2.	Visually check condition and attachment of fiberglass tips				<input checked="" type="checkbox"/>		
9.3.	Check elevator free movement	<input checked="" type="checkbox"/>	<input checked="" type="checkbox"/>		<input checked="" type="checkbox"/>		
9.4.	Check elevator hinge	<input checked="" type="checkbox"/>	<input checked="" type="checkbox"/>		<input checked="" type="checkbox"/>		
9.5.	Check play - move the stabilizer forward-rearward, upward-downward - contact the airplane manufacturer if play exceeded tolerances		<input checked="" type="checkbox"/>		<input checked="" type="checkbox"/>		
9.6.	Check security of joints at control column	<input checked="" type="checkbox"/>	<input checked="" type="checkbox"/>		<input checked="" type="checkbox"/>		
9.7.	Trim tab						
9.7.1.	Visually check condition		<input checked="" type="checkbox"/>	<input checked="" type="checkbox"/>	<input checked="" type="checkbox"/>		
9.7.2.	Check hinge		<input checked="" type="checkbox"/>	<input checked="" type="checkbox"/>	<input checked="" type="checkbox"/>		
9.7.3.	Check control cables condition				<input checked="" type="checkbox"/>		
9.7.4.	Check tension of trim tab control cables and check securing the adjusting screws				<input checked="" type="checkbox"/>		
9.7.5.	Check electrical trim - functionality				<input checked="" type="checkbox"/>		
9.8.	Lubricate per Lubricating Chart	<input checked="" type="checkbox"/>	<input checked="" type="checkbox"/>		<input checked="" type="checkbox"/>		
10.	VERTICAL TAIL UNIT						
10.1.	Visually check condition - no loose rivets, deformation, cracks, scratches and/or other damage - contact the airplane manufacturer	<input checked="" type="checkbox"/>	<input checked="" type="checkbox"/>		<input checked="" type="checkbox"/>		
10.2.	Visually check condition and attachment of fiberglass tips				<input checked="" type="checkbox"/>		
10.3.	Check rudder free movement	<input checked="" type="checkbox"/>	<input checked="" type="checkbox"/>		<input checked="" type="checkbox"/>		
10.4.	Check rudder suspensions	<input checked="" type="checkbox"/>	<input checked="" type="checkbox"/>		<input checked="" type="checkbox"/>		
10.5.	Check play - move rudder upward-downward	<input checked="" type="checkbox"/>	<input checked="" type="checkbox"/>		<input checked="" type="checkbox"/>		
10.6.	Check joints security	<input checked="" type="checkbox"/>	<input checked="" type="checkbox"/>		<input checked="" type="checkbox"/>		
10.7.	Lubricate per Lubricating Chart	<input checked="" type="checkbox"/>	<input checked="" type="checkbox"/>		<input checked="" type="checkbox"/>		
11.	COCKPIT						
11.1.	Instrument panel						
11.1.1.	Visually check condition and attachment of the instrument panel		<input checked="" type="checkbox"/>		<input checked="" type="checkbox"/>		



Event #	Event description	Inspection				Carried out by:	Inspected by:
		<input checked="" type="checkbox"/> Tick off performed inspection					
		after the first 25 hrs.	after the first 50 hrs.	every 50 hrs.	every 100 hrs.		
11.1.2.	Check condition and attachment of individual instruments		<input checked="" type="checkbox"/>		<input checked="" type="checkbox"/>		
11.1.3.	Check function of instruments				<input checked="" type="checkbox"/>		
11.1.4.	Check throttle and choke levers free movement and lock	<input checked="" type="checkbox"/>	<input checked="" type="checkbox"/>		<input checked="" type="checkbox"/>		
11.1.5.	Inspect completeness and readability of placards				<input checked="" type="checkbox"/>		
11.1.6.	Check wire integrity				<input checked="" type="checkbox"/>		
11.1.7.	Check heating and pre-heating actuator				<input checked="" type="checkbox"/>		
11.2.	Seats						
11.2.1.	Visually check seat upholstery, remove upholstery				<input checked="" type="checkbox"/>		
11.2.2.	Visually check seats and backrests condition				<input checked="" type="checkbox"/>		
11.2.3.	Check for loose rivets or any other damage on the seats				<input checked="" type="checkbox"/>		
11.2.4.	Visually check main landing gear legs attachment inside the fuselage				<input checked="" type="checkbox"/>		
11.3.	Safety harness						
11.3.1.	Visually check condition, attachment and security				<input checked="" type="checkbox"/>		
11.4.	Hand control						
11.4.1.	Remove aileron rod covers inside the cockpit		<input checked="" type="checkbox"/>		<input checked="" type="checkbox"/>		
11.4.2.	Check hand control free movement	<input checked="" type="checkbox"/>	<input checked="" type="checkbox"/>	<input checked="" type="checkbox"/>	<input checked="" type="checkbox"/>		
11.4.3.	Check play	<input checked="" type="checkbox"/>	<input checked="" type="checkbox"/>		<input checked="" type="checkbox"/>		
11.4.4.	Check joints security	<input checked="" type="checkbox"/>	<input checked="" type="checkbox"/>		<input checked="" type="checkbox"/>		
11.4.5.	Check control column stops for condition				<input checked="" type="checkbox"/>		
11.4.6.	Pitostatic system drainage, see 2.3.20				<input checked="" type="checkbox"/>		
11.4.7.	Lubricate per Lubricating Chart	<input checked="" type="checkbox"/>	<input checked="" type="checkbox"/>		<input checked="" type="checkbox"/>		
11.5.	Rudder control						
11.5.1.	Check stiffness of movement	<input checked="" type="checkbox"/>	<input checked="" type="checkbox"/>	<input checked="" type="checkbox"/>	<input checked="" type="checkbox"/>		
11.5.2.	Check joints security	<input checked="" type="checkbox"/>	<input checked="" type="checkbox"/>		<input checked="" type="checkbox"/>		
11.5.3.	Check stops at pedal control cables				<input checked="" type="checkbox"/>		
11.5.4.	Check condition and security of cables	<input checked="" type="checkbox"/>	<input checked="" type="checkbox"/>		<input checked="" type="checkbox"/>		
11.5.5.	Check hydraulic brake system for leaks - add brake fluid if needed	<input checked="" type="checkbox"/>	<input checked="" type="checkbox"/>	<input checked="" type="checkbox"/>	<input checked="" type="checkbox"/>		
11.5.6.	Lubricate per Lubricating Chart	<input checked="" type="checkbox"/>	<input checked="" type="checkbox"/>		<input checked="" type="checkbox"/>		
11.6.	Flap and trim control, Towing mechanism control						
11.6.1.	Check free movement of levers	<input checked="" type="checkbox"/>	<input checked="" type="checkbox"/>	<input checked="" type="checkbox"/>	<input checked="" type="checkbox"/>		
11.6.2.	Check operation of flap control lever lock (push button)	<input checked="" type="checkbox"/>	<input checked="" type="checkbox"/>		<input checked="" type="checkbox"/>		
11.6.3.	Lubricate per Lubricating Chart	<input checked="" type="checkbox"/>	<input checked="" type="checkbox"/>		<input checked="" type="checkbox"/>		
11.7.	Complete lubricating per Lubricating Chart	<input checked="" type="checkbox"/>	<input checked="" type="checkbox"/>		<input checked="" type="checkbox"/>		
11.8.	Install seats upholstery and covers						
11.9.	Engine Test Run (see FM) <ul style="list-style-type: none"> • idling • throttle and choke levers operation • acceleration - deceleration • r.p.m. drop with either magneto switched off • max. r.p.m. • test brake system efficiency 	<input checked="" type="checkbox"/>	<input checked="" type="checkbox"/>	<input checked="" type="checkbox"/>	<input checked="" type="checkbox"/>		
11.10.	Test flight	<input checked="" type="checkbox"/>	<input checked="" type="checkbox"/>	<input checked="" type="checkbox"/>	<input checked="" type="checkbox"/>		
11.11.	Clean the airplane surface (only for service station)	<input checked="" type="checkbox"/>	<input checked="" type="checkbox"/>	<input checked="" type="checkbox"/>	<input checked="" type="checkbox"/>		

Document No.: SSM2008MAIPUS	Date of Issue: March 01, 2009	Revision: -	4-15
--	--	-----------------------	-------------



4.5 Fluids

The fluids are: fuel, engine oil, liquid coolant and brake fluid.

Filling locations can be seen in the Figure below. Fuel and Brake fluid filling locations are described in 4.5.4 and 4.5.3 respectively.



Fig. Filling locations in engine compartment
1- oil tank,
2 - liquid coolant tank
3 – brake fluid central bottle



4.5.1 Engine oil

4.5.1.1 Recommended brands

The recommended oil brands are listed in Service Instruction SI-18-1997, which is enclosed with this Maintenance manual.

4.5.1.1.1 Table of oils

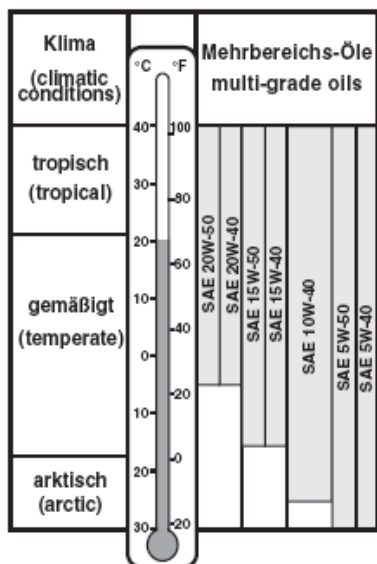

4.5.1.2 Oil quantity

The total oil quantity in the Rotax 912 lubricating system amounts to 0.9 U.S. gall (3.5 liters). Prior to oil check, turn the propeller by hand (ignition switched off!) several times to pump oil from the engine into the oil tank, or leave the engine idle for 1 minute. The oil level in the oil tank should be between the min. and max. marks and should not be below min. mark.

4.5.1.3 Oil filling

Type of maintenance: line.

Authorization to perform: - Aircraft owner (only for ELSA)
 - Sport pilot or higher

Tools needed:

- flat screwdriver to remove upper engine cowling
- suitable funnel

Parts needed: recommended brand of oil

Instructions:

1. Remove upper cowling.
2. Unscrew oil tank cap.
3. Insert funnel and fill oil.
4. Remove funnel, screw oil tank cap, check cap proper attachment.
5. Mount upper cowling

The oil tank is located in the engine compartment and is accessible when engine upper cowling is removed. Oil quantity is measured by wire-gauge in the oil tank - see previous paragraph.

Task proper accomplishment check: check the oil tank cap is fitted properly.



4.5.1.4 Oil emptying

Type of maintenance: line.

Authorization to perform: - Aircraft owner (only for ELSA)
- Sport pilot or higher

Tools needed:

- flat screw driver to remove upper engine cowling
- Philips tip screw driver
- nut wrench No. 17
- a suitable oil can or sump

Parts needed: recommended brand of oil

Instructions:

Unscrew the plug located on the bottom of the oil tank to empty out the oil.

To empty oil from the engine, pull out the return hose located on the bottom of the engine from oil tank (release hose clip first) and lower hose end to oil can.

It is recommended to empty oil when the engine is warm.

Task proper accomplishment check: none



4.5.1.5 Oil filter replacement

Remove engine cowlings. Unscrew the elbow on the left front (as viewed in flight direction) exhaust pipe using nut wrench size 12. Loose a clamp of that pip on the exhaust muffler using wrench 13. Disconnect the elbow from the engine and turn the exhaust pipe slightly to move it from the oil filter. Replace oil filter by a new one. See Maintenance Manual (Line Maintenance) for ROTAX Engine Type 912 Series for replacement instructions. Connect the elbow to the engine and tighten the nuts slightly by fingers. Set exhaust pipe clearance from the radiator hose and oil filter. Clearance from the radiator hose must be min. 0.8 in (20 mm) and approximately 0.2 in (5 mm) from oil filter. When clearances are set, tighten the elbow and clamp. Re-install the engine cowlings after oil re-filling.

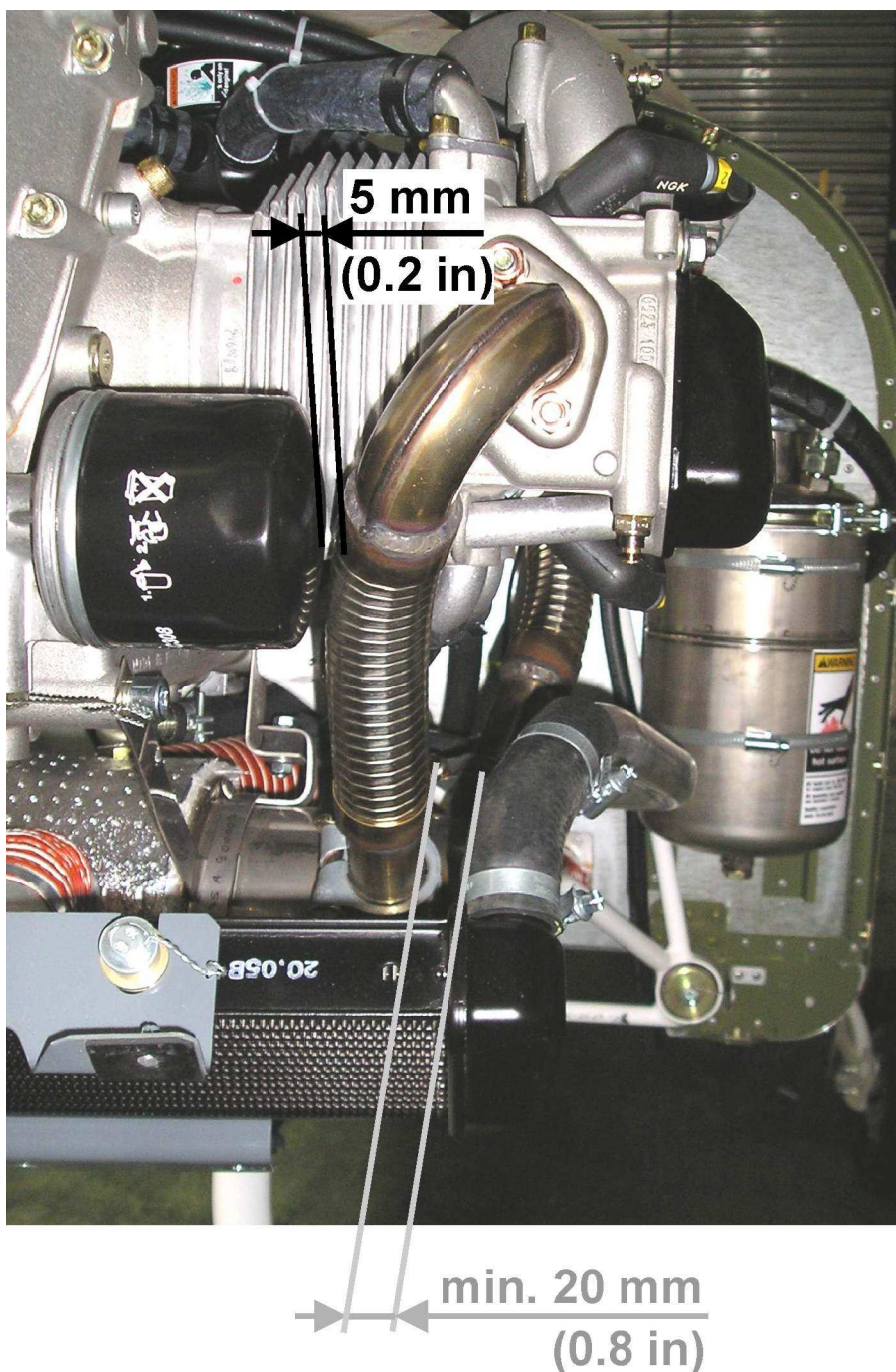



4.5.2 Coolant

4.5.2.1 Recommended types

Refer to the Rotax 912 Operator's Manual for recommended coolant types. The "BASF Glysantin Anticorrosion", "FRIDEX G 48" or "Glysantin Protect Plus (produced by BASF)" is recommended by the engine manufacturer. The engine manufacturer also recommends the use of antifreeze concentrate during cold weather operation.

4.5.2.2 Coolant quantity

Total coolant quantity is about 0.4 U.S. gall (1.5 liters).

4.5.2.3 Coolant refilling

Type of maintenance: line.

Authorization to perform:

- Aircraft owner (only for ELSA)
- Sport pilot or higher

Tools needed: flat screw driver

Parts needed: recommended type of coolant

Instructions:

1. Remove upper engine cowling.
2. Unscrew coolant expansion tank cap.
3. Check coolant quantity and fill some amount if needed.
4. Screw tank cap back
5. Mount upper cowling back.

The expansion tank located in the engine compartment is used for filling. In addition to that, an overflow bottle is attached on the firewall to absorb coolant in the case of engine overheating.

Task proper accomplishment check: check proper attachment of coolant tank cap after refilling, check proper attachment of the upper engine cowling.

4.5.2.4 Coolant emptying

Type of maintenance: line.

Authorization to perform:

- Aircraft owner (only for ELSA)
- Sport pilot or higher

Tools needed: flat screw driver

suitable container for coolant

Parts needed: none

Instructions:

1. Remove upper engine cowling.
2. Place suitable container under the engine.
3. Check coolant quantity and fill some amount if needed.
4. Disconnect the hose going from the radiator into the pump (on the lowest part of the cooling system)
5. Empty coolant into a container.
6. Mount hose back.
7. Mount upper cowling back.

Task proper accomplishment check: check proper hose attachment
check proper attachment of the upper engine cowling.



4.5.3 Brake fluid

4.5.3.1 Recommended types

Standard Brake System

Only brake fluid of J 1703c classification should be used for hydraulic brake system (type for middle hard or hard operation).

Czech Rep.	Foreign
<ul style="list-style-type: none"> • Syntol HD 205 or • Syntol HD 260 	<ul style="list-style-type: none"> • ATE Blau • STOP SP 19 • MOBIL Hydraulic Brake Fluid 550 • BP Brake Fluid • PENTOSIN Super Fluid • AGIP F. 1 Brake Fluid Super HD • NAFTAGAS AT-2 • INA UK-2.

These brake fluid types may be blended as required and refilled in any mixing proportion.

MATCO Brake System

4. All o-rings in the brake and master cylinder assembly are buna nitrile and are not compatible with automotive glycol based brake fluid. ONLY red aircraft fluid (Mil-H-5606) or other suitable petroleum-based or silicon-based fluid should be used.

4.5.3.2 Brake fluid refilling

Type of maintenance for the other instruments: line.

Authorization to perform:

- Aircraft owner (only for ELSA)
- Sport pilot or higher

Tools needed: screwdriver to remove upper cowling

Parts needed: recommended brake fluid

Instructions:

Brake fluid refilling is necessary when a low brake system efficiency occurs due to a fluid leak.

A brake fluid is filled into reservoir located in the engine compartment on the firewall. A brake fluid level must be approx. 1 inch in the reservoir – see figure below.

Step repeatedly on the pedal during refilling. Bleed the system after refilling.



Task proper accomplishment check:brake fluid level in the reservoir approx. 1 inch
check efficiency of brake system



4.5.3.3 Brake fluid emptying

Type of maintenance: line.

Authorization to perform:

- Aircraft owner (only for ELSA)
- Sport pilot or higher

Standard Brake System

Tools needed:

- wrench No. 7
- hose with inner diameter suitable for bleeding screw
- suitable cup for brake fluid

Parts needed: recommended brake fluid

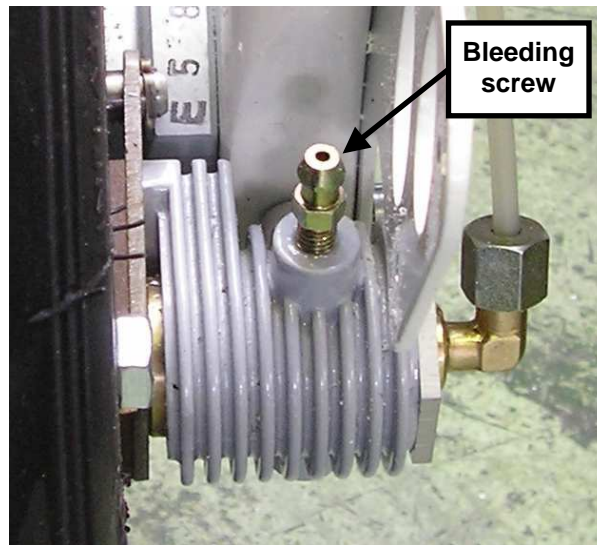

Instructions:

Brake fluid thickens during aircraft operation and absorbs water. This condition causes brake system failures. It is not possible to determine when this may occur. The best way to prevent trouble is to change the brake fluid every year.

1. Insert hose on the bleeding screw and hold hose end in suitable cup.
2. Release bleeding screw and let flow brake fluid into cap.
3. Step repeatedly on the pedal during emptying.
4. Tighten bleeding screw and remove hose from it.
5. Repeat above procedure for the other brake.

Task proper accomplishment check no brake fluid flow during item No. 3 executing.

MATCO Brake System

The procedure is the same as described above.



4.5.4 Fuel

4.5.4.1 Recommended brands

The following fuels can be used :

	Usage / Description	
	912 UL / A / F	912 ULS / S
MOGAS		
European standard	EN 228 Normal ¹⁾	
	EN 228 Super ¹⁾	EN 228 Super ²⁾
	EN 228 Super plus ¹⁾	EN 228 Super plus ²⁾
Canadian standard	CAN/CGSB3.5 Quality 1 ³⁾	CAN/CGSB3.5 Quality 3 ⁴⁾
US standard	ASTM D4814	ASTM D4814
AVGAS		
US standard	AVGAS 100 LL (ASTM D910)	AVGAS 100 LL (ASTM D910)

¹⁾ min. ROZ 90

²⁾ min. ROZ 95

³⁾ min. AKI* 87

⁴⁾ min. AKI 91

AVGAS 100LL places greater stress on the valve seats due to its high lead content and forms increased deposits in the combustion chamber and lead sediments in the oil system. Thus it should only be used in case of problems with vapor lock or when other types of gasoline are unavailable.

■ **CAUTION:** Use only fuel suitable for the respective climatic zone.

◆ **NOTE:** Risk of vapour formation if using winter fuel for summer operation.

■ **CAUTION:** Obey the latest edition of Service Instruction SI-912-016 for the selection of the correct fuel.

4.5.4.2 Fuel quantity

Total fuel capacity is about 31.7 U.S. gallons (120 litres).
Keep the maximum permitted take-off weight in mind when fueling.



4.5.4.3 Fueling

Type of maintenance: line.

Authorization to perform: - Aircraft owner (only for ELSA)
- Sport pilot or higher

Tools needed: funnel (for filling from petrol can)

Parts needed: none

Instructions:

Precaution

The following precautions should be maintained during fueling to prevent fire.

WARNING

- No smoking or open flames during fueling!
- Fire extinguisher should be within reach!
- Under no circumstances add fuel with the engine running!
- Connect the aircraft to ground prior fueling.
- No person in the cockpit during fueling!

A fuel tank filler is located on the upper side of the each wing (see photo).

CAUTION

It is highly recommended to pour gasoline through a filter if it was not tested for water content. After fueling, allow 20 min. for water to settle out on the bottom. Drain off some fuel and look for water.



Fig. Fuel tank filler neck



1. Connect the aircraft to the ground.
2. Open fuel tank filler
3. Insert fuel delivery nozzle or a funnel into the filler.
4. Fill required quantity of fuel.
5. Remove nozzle.
6. Close fuel tank filler by its cap.

Task proper accomplishment check: check the fuel tank cap is home screwed and required amount of fuel is in the tank (according to fuel gauge).

4.5.4.4 Fuel emptying

Type of maintenance: line.

Authorization to perform: - Aircraft owner (only for ELSA)
- Sport pilot or higher

Tools needed: none

Parts needed: a petrol can to be placed under the aircraft

Instructions:

Precaution

Use the same precautions as during fueling.

Draining procedure

1. Put the vessel under the drain valve.
2. Open fuel tank cap to speed up draining.
3. Using screwdriver (or appropriate jig) press and turn draining valve to the left to open it.
4. Drain fuel. If it is necessary to drain all fuel, push airplane tail down (almost to the ground) to allow drain of the all unusable fuel.
5. Using screwdriver (or appropriate jig) turn draining valve to the right to close it.
6. Close fuel tank cap.
7. Repeat procedure for the opposite tank.

WARNING

Do not smoke or have open any flame during draining!

Task proper accomplishment check: check the drain valve closing



4.6 Lubrication

Type of maintenance: line.

Authorization to perform:

- Aircraft owner (only for ELSA)
- Sport pilot or higher

Authorized person can lubricate the aircraft in all lubricating points according to 4.6.2.2.

4.6.1 Lubrication fundamentals

There are some generally inaccessible joints and control system parts inside the wings and fuselage, which have been cleaned and lubricated during airplane assembly. Lubrication of these will be performed during a periodic inspection.

There are some parts, e.g. landing gear, which are exposed to external conditions and to varying loads. These parts will be inspected during pre-flight and during periodical inspections. These should be lubricated as is necessary, but at least in the intervals specified below.

4.6.2 Recommended lubricants

4.6.2.1 Greases

Greases are mineral oils thickened with calcic, sodium, lithium or any other thickeners of aliphatic acids.

The greases do not SAE classification and their usage is recommended by manufacturer. Grease may be applied all the year round.

The following greases are recommended:

- waxy, semi-solid or butyraceous consistency and water resistant. They are used at very low temperatures (-22 F, -30 C) and at high temperatures (248 F, 120 C)
-

Czech	Foreign
MOGUL MOLYKA G (or equivalent)	AEROSHELL GREASE 22
	AEROSHELL GREASE 11MS
	AEROSHELL GREASE 23C
	SHELL RETINAX HDX2
	SHELL RETINAX EPX2
	(or equivalent)

4.6.2.2 Lubricating points

Unit	Lubricating point	after the first 25 hrs.	Every 50 hrs.	Every 100 hrs	Lubricant
Prop	<ul style="list-style-type: none"> Adjustable props acc. to Prop Manual 				
Engine	<ul style="list-style-type: none"> oil change acc. to Engine Manual 				
	<ul style="list-style-type: none"> carburetor control cable at inlet into the bowden (in engine compartment) 	X	X		oil
Nosewheel landing gear	<ul style="list-style-type: none"> choke control cable at inlet into the termination (in engine compartment) 	X	X		oil
	<ul style="list-style-type: none"> landing gear leg in the area of bushing 	X	X	X	oil
Main landing gear	<ul style="list-style-type: none"> bearings in pull rod terminals of landing gear control 	X	X	X	oil
	<ul style="list-style-type: none"> pins of brake pads holders 		X		MOGUL MOLYKA G, foreign greases
Wing	<ul style="list-style-type: none"> all movable joints of wing folding mechanism (if mounted) 	X	X	X	MOGUL MOLYKA G, foreign greases
Ailerons	<ul style="list-style-type: none"> hinges 		X		oil
	<ul style="list-style-type: none"> control hinge pin 			X	MOGUL MOLYKA G, foreign greases
	<ul style="list-style-type: none"> two-armed aileron control levers inside the wing 			X	MOGUL MOLYKA G, foreign greases
	<ul style="list-style-type: none"> hinge joint of rods under the wing fillet 			X	MOGUL MOLYKA G, foreign greases
Flaps	<ul style="list-style-type: none"> hinges 	X	X		oil
	<ul style="list-style-type: none"> all movable joints under the quadrant cover between the seats 			X	MOGUL MOLYKA G, foreign greases
	<ul style="list-style-type: none"> All movable joints under the baggage compartment bottom cover 			X	MOGUL MOLYKA G, foreign greases
	<ul style="list-style-type: none"> Flaps control pins (at a flap root) 		X		MOGUL MOLYKA G, foreign greases
HTU	<ul style="list-style-type: none"> elevator hinge 		X		oil
	<ul style="list-style-type: none"> swivel bearing in the elevator control rod termination 			X	MOGUL MOLYKA G, foreign greases
VTU	<ul style="list-style-type: none"> rudder suspensions 			X	MOGUL MOLYKA G, foreign greases
	<ul style="list-style-type: none"> rudder control cables at attachment to the rudder 			X	MOGUL MOLYKA G, foreign greases
Trim tab	<ul style="list-style-type: none"> trim tab hinge 	X	X		oil
	<ul style="list-style-type: none"> control cables at inlets in the terminations 			X	MOGUL MOLYKA G, foreign greases
Stick control	<ul style="list-style-type: none"> All movable joints in the cockpit 			X	MOGUL MOLYKA G, foreign greases
Rudder control	<ul style="list-style-type: none"> All movable joints in the cockpit 			X	MOGUL MOLYKA G, foreign greases
	<ul style="list-style-type: none"> The passages of rudder control cables 			X	MOGUL MOLYKA G, foreign greases
	<ul style="list-style-type: none"> Brake system control cables at inlets in the bowdens (at brake pedals) 			X	MOGUL MOLYKA G, foreign greases



4.7 Mechanism adjustments

4.7.1 Torque moments

Metric thread		Strength class				
		4.8	5.8	8.8	10.9	12.9
M4	N.m		1,67			
	kg.m		0,17			
M5	N.m		3,45			
	kg.m		0,35			
M6	N.m	5,39	6,86	9,80	13,72	16,67
	kg.m	0,55	0,70	1,00	1,40	1,70
M7	N.m	8,82	10,78	14,70	20,59	25,49
	kg.m	0,90	1,10	1,50	2,10	2,60
M8	N.m	12,74	15,69	22,55	32,36	38,24
	kg.m	1,30	1,60	2,30	3,30	3,90
M10	N.m	24,51	31,38	44,12	61,78	73,54
	kg.m	2,50	3,20	4,50	6,30	7,50
M12	N.m	42,16	52,95	74,53	104,93	125,52
	kg.m	4,30	5,40	7,60	10,70	12,80
M14	N.m	66,68	78,54	117,67	164,75	196,13
	kg.m	6,80	8,00	12,00	16,80	20,00
M16	N.m	93,16	107,87	164,75	225,55	274,58
	kg.m	9,50	11,50	16,80	23,00	28,00
M18	N.m	137,29	171,61	245,16	343,23	411,87
	kg.m	14,00	17,50	25,00	35,00	42,00
M20	N.m	176,51	225,55	313,81	441,29	539,36
	kg.m	18,00	23,00	32,00	45,00	55,00
M22	N.m	225,55	284,39	392,26	558,97	676,65
	kg.m	23,00	29,00	40,00	57,00	69,00
M24	N.m	313,81	392,26	549,17	755,11	970,85
	kg.m	32,00	40,00	56,00	77,00	99,00
Ultimate strength (MPa)		420	500	880	1040	1220
ϕ in %		(14)	7	12	8	8
Yield point (MPa)		330	400	640	940	1100

Conversion: 1 N.m = 0.74 lb.ft

Conversion may be found at e.g. http://www.unitconversion.org/unit_converter/torque-ex.html

Torque moment formula (valid for all bolt sizes):

$$M_{kmax} = 1,065 \times \frac{d \cdot \sigma \cdot S}{1000 \cdot m}$$

Legend:

Mk..... torque moment N.m
d..... bolt shank diam. mm
σ..... min. yield point MPa
m..... safety factor (m=1,25 for σ<500 MPa; m=1,43 for σ>500 MPa)
s..... lead of helix mm



4.8 Necessary maintenance tools

No special tools are needed for the *SportStar MAX* maintenance. Tools used for automobile maintenance are suitable.

As the *SportStar MAX* is European design, metric tools are recommended for its maintenance. The aircraft manufacturer can provide a set of such metric tools.

4.9 Access holes

The following are the inspection and access holes:

- Screw caps on the wings lower surface - access to the aileron control rods and levers and to the pitot/static installation in the left half of the wing
- Screw cap on the fuselage lower surface under the baggage compartment close to the fuel tank - access to the fuel tank installation
- Screw cap on the fuselage lower surface in the middle of the rear section - access to the elevator control rods and a lever
- Wing fillets which cover space between the fuselage and wing - access to the wing-fuselage suspensions (wing folding mechanism)
- Cover sheet of Control stick system in the cockpit



4.10 Brake system efficiency adjustment

4.10.1 Brake pad replacement

Type of maintenance for the other instruments: line.

Authorization to perform:

- Aircraft owner (only for ELSA)
- Sport pilot or higher

Tools needed:

- jacks or supports
- pliers to remove locking wire
- flat screw driver to bend locking wire

Parts needed:

1. Brake pads 4 pcs P/N E5 50-50 21
2. Stainless locking wire 2 pcs dia. 1 mm

Instructuions:

Brake pad replacement is only performed when a pad is worn-out.

Brake pad replacement procedure

1. Jack the airplane for easier acces to brake pads.
2. Remove the locking wire, shift the pins out and remove the brake pads
3. Mount a new brake pads - insert the upper pin and insert stainless locking wire to pin hole.
4. Insert lower pin, rotate it so that locking wire from upper pin can get through lower pin hole.
5. Get through locking wire through lower pin hole. One wire is used for both pins.
6. Secure both pins with bend of the locking wire around the pins.
7. Lower the airplane.

Task proper accomplishment check: check securing of both pins after replacement
check efficiency of brakes



4.10.2 Bleeding

Type of maintenance: line.

Authorization to perform: - Aircraft owner (only for ELSA)
- Sport pilot or higher

Tools needed: nut wrench No. 7 to release bleeding screw

Parts needed: none

Instructions:

Standard Brake System

It is important to thoroughly bleed the brake system. Otherwise the system function may be unreliable and the brakes may fail. There are two main reasons for air entering the brake system:

1. Disconnected or loose hoses
2. Insufficient quantity of brake fluid

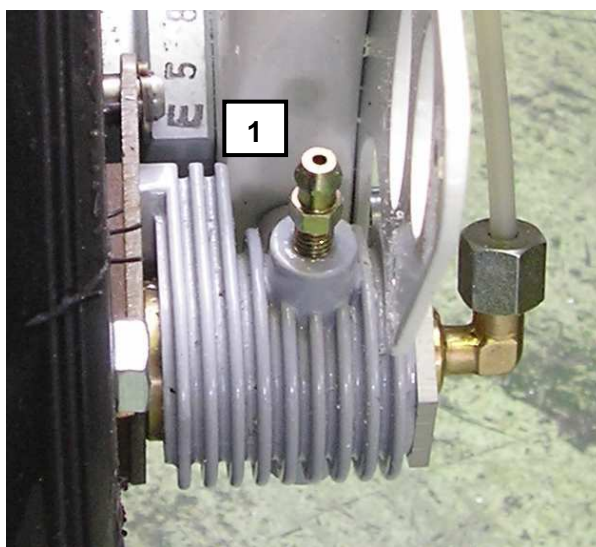

Fig. Brake system bleeding
1- Bleeding screw

Procedure:

1. Loosen the bleeding screw in the brake cylinder
2. Step repeatedly on the pedal to bleed the brake system
3. Tighten the screw
4. Repeat several times or until the pedal offers resistance against motion (feels firm)

NOTE

If the brake efficiency remains unsatisfactory after bleeding or if the pedal motion is excessive, fill with brake fluid and bleed the system again. Continue until all the air is out of the system

Task proper accomplishment check: check tightening of the bleeding screw
check function and efficiency of brakes

MATCO Brake System

For the bleeding of the MATCO MHMHE 6B1.25 main wheel refer to the *MHE6B & MHE6B-C External caliper, 6" E- Series, Wheel and Brake, L. Bleeding the Brake System* available at <http://matco.veracart.com/pdf/MHE6BMANUALp.pdf?lit=2411&ict=23>



4.11 Control surfaces deflection setting

Type of maintenance: line.

Authorization to perform: - Aircraft owner (only for ELSA)
- Sport pilot or higher

Tools needed: refer to paragraphs below

Parts needed:

- a bevel protractor
- a clip to attach protractor to measured control surface
- cotter pin 1.6 x 16 to secure some nuts

Instructions: refer to paragraph below

Task proper accomplishment check: check securing of all joints
check proper tightening of all screws
check the deflections comply with Control Surfaces Deflection Record

Control surface deflections of a new aircraft are set by the manufacturer. Deflections are adjusted to values specified in the Control Surfaces Deflection Record enclosed in this Manual.

A neutral position of the control surfaces and controls is used as a base for adjustment of deflections.

4.11.1 Aileron deflection adjustment

Tools needed:

- wrench No. 9, 10, 13,
- allen wrench No. 3,
- flat screw driver
- pliers

Instructions:

A range of deflections are set using adjustment screws on lateral control stops located on a console of the left/right control column.

The aileron neutral position can be adjusted with the adjustable end of the short rod inside the cockpit. Or with the adjustable end of the longer rod inside the wing (when the screw cap on the lower wing surface is removed).

The aileron differential (difference between a lower and upper deflection) can be adjusted with the adjustable end of the rod connecting the two-armed lever inside the wing and the hinge. The adjustable rod end is accessible when an aileron is deflected upward.

4.11.2 Flap deflection adjustment

Tools needed:

- wrench No. 5.5, 9 (2x), 10, 13,
- pliers

Instructions:

Flaps deflection is determined by cut-outs in a changing gate on the flap control lever inside the cockpit. Use the following procedure to adjust flap deflection:

Remove the baggage compartment bottom cover which will allow access to a rod connecting the flap control lever and a lever welded on a tube connecting the left and right flap. Use the adjustable rod end to adjust the flaps in the position "RETRACTED" Or you can use eccentric pin to set retracted position – see below.

The deflection of the left flap against the right flap may be adjusted when the eccentric pin is moved a slight amount. The pin is inserted into the groove of the flap root.

See Figure in par. 2.3.12.10 for adjustment points.



4.11.3 Elevator deflection adjustment

Tools needed:

- wrench No. 9 (2x), 13
- pliers

Instructions:

The range of elevator deflection is determined by the control stick stops setting. The "Push in" stop may be adjusted with an adjustment screw. To adjust an upward deflection, fully pull the control stick rearward. Then measure the elevator upward deflection and compare it with the one specified – if required adjust the deflection with the adjustable end of the elevator control rod or with the adjustable end of the rod below the baggage compartment cover. When the upward elevator deflection is adjusted, fully push the control stick and adjust a stop so that an elevator downward deflection corresponds with that one specified.

See Figure in par. 2.3.12.7 for adjustment points.

4.11.4 Rudder deflection adjustment

Tools needed:

- wrench No. 8, 10

Instructions:

The rudder deflections are set by the aircraft manufacturer. If necessary the rudder deflections can be adjusted by adjustable stops located on the rudder control cable in the cockpit (see para. 2.3.12.9). Side cockpit upholstery must be removed first.

4.11.5 Trim tab adjustment

Tools needed:

- wrench No. 10 (2x)
- allen wrench No. 4
- pliers

Instructions:

The following may be adjusted:

- a) The position of the trim tab control lever may be adjusted against a groove in the quadrant between the seats.
Loosen the bolts which clamp the ends of the trim tab control cables on the upper/lower tab surface. Then set the trim tab control lever in the desired position, slightly tighten the cables and retighten the bolts.
- b) Trim tab deflections
Trim tab deflection may be adjusted using the adjustment bolts which clamp the ends of the control cables. The adjustment bolts are on the upper/lower tab surface – see Fig. in par. 2.3.12.11.



4.12 Steerable nosewheel landing gear adjustment

Type of maintenance: line.

Authorization to perform: - Aircraft owner (only for ELSA)
- Sport pilot or higher

Tools needed:

- wrench No. 9, 10,
- pliers

Parts needed: cotter pin 1.6 x 16

Instructions:

A steerable nosewheel adjustment is necessary so the airplane tracks during straight taxiing with engine idling (to eliminate prop turning moment) with rudder pedals held in neutral position (no crosswind!).

Procedure:

1. Lift the nosewheel and neutralize wheel and rudder pedals
2. Adjust the nosewheel control using the adjustable rod ends.

Task proper accomplishment check: check straight taxiing at idle with rudder pedals neutralized.

4.12.1 Rubber shock absorber replacement

Type of maintenance: line.

Authorization to perform: - Aircraft owner (only for ELSA)
- Sport pilot or higher

Tools needed: pliers to remove cotter pin

Parts needed: new rubber rope (bungees),
cotter pins

Instructions:

Perform rubber shock absorber replacement when rubber rope is damaged or excessively worn down.

Procedure:

1. Remove cotter pins from the hollow pin attaching a rubber rope
2. Remove hollow pin
3. Remove rubber rope from the nose landing gear leg
4. Mount a new rubber rope at the leg, sling over pin
5. Insert a hollow pin back
6. Secure by two cotter pins

Task proper accomplishment check: check function of nose wheel shock absorbing.

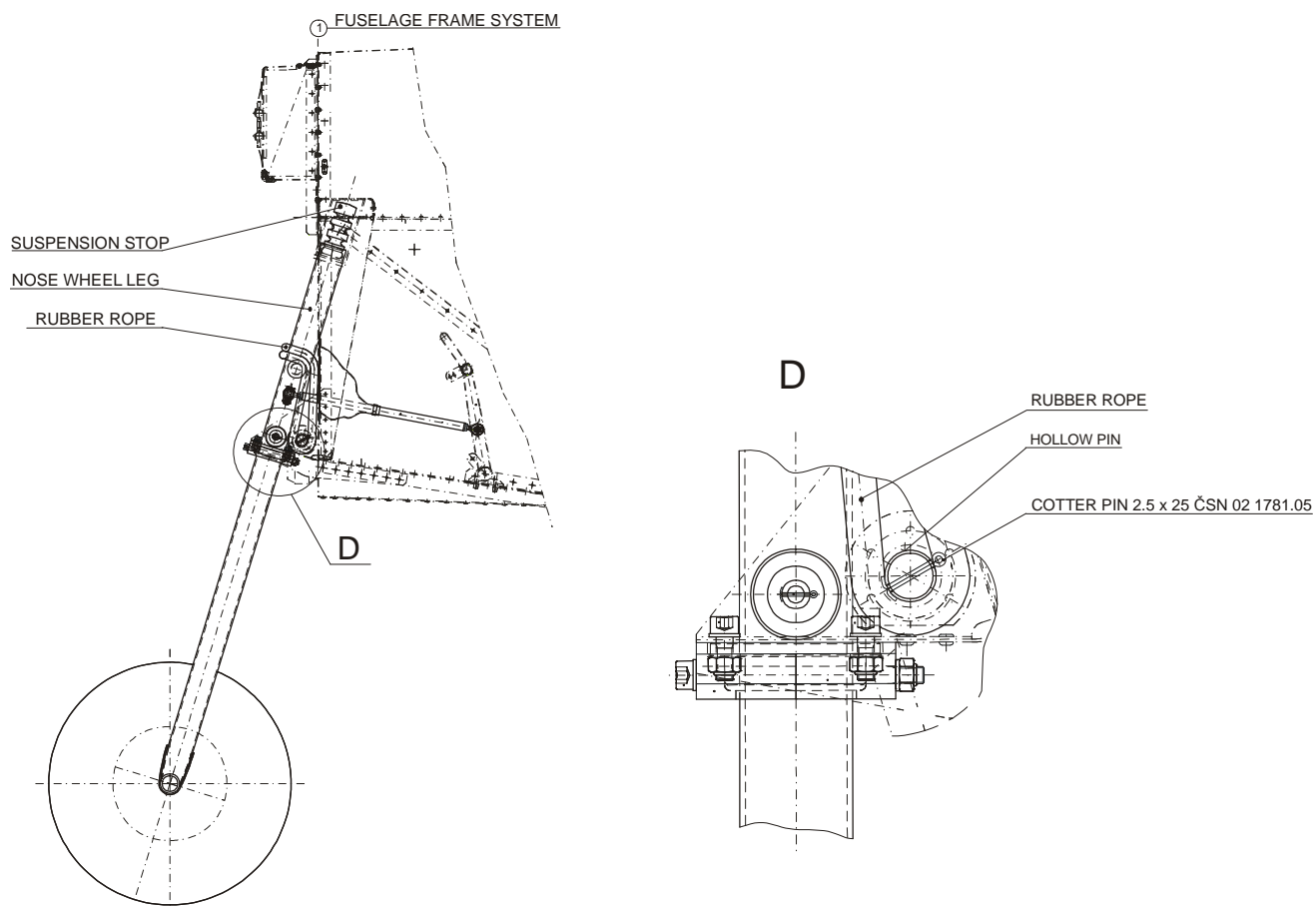

4.13 Engine idle adjustment

Type of maintenance: line.

Authorization to perform:

- Aircraft owner (only for ELSA)
- Sport pilot or higher

Tools needed: flat screw driver

Parts needed: none

Instructions:

1. Remove upper engine cowling.
2. Use chocks under main wheels.
3. Start engine, set idle.
4. A mechanic shall go alongside the wing leading edge, very carefully considering rotating propeller .
5. Mechanic adjusts the engine run at idle to increase / decrease engine speed Use adjustment screw on the carburetors to set engine speed approximately 1400 R.P.M.

WARNING

BECAUSE THE ENGINE IDLE IS ADJUSTED ON A RUNNING ENGINE, USE EXTREME CAUTION NEAR THE PROPELLER.

6. Stop the engine

Task proper accomplishment check: check engine run at he idle, it must be smooth



4.14 Tire inflation pressure

Type of maintenance: line.

Authorization to perform:

- Aircraft owner (only for ELSA)
- Sport pilot or higher

Tools needed:

- tire valve adapter
- air pump or compressor
- manometer

Parts needed: none

Instructions:

Tire pressures are noted on placards located on the aircraft. Use the adapter supplied with the aircraft to inflate the nosewheel. A car tire pump or compressor, or pressure bottle may be used for inflating the wheels.

Nose wheel pressure:

Cheng Shin 15 x 6.00 – 6160 + 20 kPa / 17 + 3 psi
Sava tire 14x4.....160 + 20 kPa / 23 + 3 psi

Main wheel pressure:

Sava tire 14x4.....180 + 20 kPa / 26 + 3 psi
Cheng Shin 15 x 6.00 – 6120 + 20 kPa / 17 + 3 psi
GOOD YEAR 15 x 6.00 – 680 + 20 kPa / 12 + 3 psi

Task proper accomplishment check: check tire pressure.



4.15 Cleaning and care

Cleaning and care may be performed by Aircraft owner (only for ELSA) or Sport pilot or higher.

4.15.1 Airplane care outlines

Use mild detergents to clean the exterior surfaces. Oil spots on the surfaces (except the canopy!) may be cleaned with gasoline or strong detergents such as 409.

Upholstery covers can be removed from the cockpit, brushed or washed in lukewarm water with a laundry detergent. Dry the upholstery before reinstalling.

4.15.2 External surfaces cleaning

The external metal surfaces and fiberglass parts (cowlings, wingtips etc.) of the airplane are protected with weather-proof paint. Wash the airplane surface with lukewarm water and car wash type detergents. Then wash the airplane with water and sponge dry. It is recommended to protect painted external surfaces twice a year, by applying an automotive type polish. Use only on a clean and dry surface, and polish with a soft flannel rag.

CAUTION

- Never wipe a dry surface – the surface may be scratched by dusts and dirt
- Never apply any chemical solvents
- Repair a damaged painted surface (see par. 5.6) as soon as possible to prevent corrosion

4.15.3 Interior cleaning

Keep in mind the following:

- Remove any loose objects from the cockpit
- Vacuum the interior, upholstery and carpets
- Wipe the upholstery using a rag with lukewarm water and mild laundry detergent. Then dry or remove the seat upholstery, side panels, carpets and clean with lukewarm water and/or carpet cleaners, upholstery cleaners. Dry thoroughly before reinstallation.
- Clean the cockpit canopy interior surface (see par.4.15.4) below.

4.15.4 Cockpit canopy cleaning

The canopy may be cleaned by washing it with lukewarm water and car or laundry type detergents. Use a clean, soft cloth. Then use a suitable polisher on the canopy such as WEISS POLIERPASTE, WEIS SPEZIAL-SPRUHREINIGER, WEIS SPEZIAL TUCHTER.

CAUTION

- Never clean dry canopy
- Never apply gasoline or chemical solvents!
- Cover the canopy with a cover sheet



4.15.5 Engine maintenance

Refer to the engine manufacturer's instructions for engine maintenance.

4.15.6 Propeller maintenance

Refer to the propeller manufacturer's instructions for engine maintenance.



4.15.7 Winter operation

4.15.7.1 General

It is considered a winter operation, if the outside temperature falls below 41°F (+5 °C).

4.15.7.2 Preparing the aircraft for winter operation

Type of maintenance: line.

Authorization to perform: - Aircraft owner (only for ELSA)
- Sport pilot or higher

Aircraft airframe

- Lubricate the aircraft per Lubricating Chart (100 hr. Inspection) if the last inspection was not within 6 months
- Check and adjust rudder control cable prestress
- Check cockpit canopy rubber packing – replace if damaged
- Check fuel tank venting
- Check attachment of wing, ailerons, flaps and tail units; lubricate per Lubricating Chart

Engine

Refer to the Engine Manual for more details.

The following should be done:

- Add Anti-freeze to the cooling system as required (usually a 50/50 mix.)
- Change the oil (see Engine Manual or Service instructions)
- Check the spark plug gaps

If low cylinder head or oil temperatures occur during operation under low outside temperature, then do the following:

- Cover a portion of the radiator face using an aluminium sheet, insert it between the radiator and the lower engine cowling.
- Cover the oil cooler face (or a part of face) using an aluminum sheet attached with a suitable adhesive tape.
- Cover the Reduction gear unit by means of a car engine cover
- Cover the oil filter (see instructions for Reduction gear unit)
- Cover the oil tank (see instructions for Reduction gear unit)

4.15.7.3 Operation

Preflight inspection

In addition to the Pre-flight inspection described in the AOI, the following must be done:

- Remove all snow from the airplane surfaces, and remove any icing using hot air
- Check the control surfaces for free movement. Check the slots of the control surfaces and flaps. Remove any snow or ice
- Check the fuel tank vent hose for openness before each flight
- Check fuel system (fuel filter) for debris, if found, empty the fuel tank and refill with fresh fuel
- Check fuel for water prior filling (use of water separator/filter is recommended)
- Drain fuel tank (drain valves are located on the bottom side of the each wing), drain a small quantity of fuel; check for water and other contaminants until fuel is clean and clear.



Pre-heating engine and oil

It is permissible to start an engine without pre-heating if the outside air temperature is not below +5 °C. Pre-heat the engine and oil if air temperature falls below 41°F (+5 °C). Use suitable air heater or a dryer.

WARNING
NEVER USE OPEN FIRE TO PRE-HEAT AN ENGINE!

Blow hot air from the front into the hole around the prop (engine covered with fiberglass cowlings). The temperature of the hot air should not exceed 212°F (100°C) at air heater output. Warm up the oil tank along with the oil in the engine. Pre-heat until cylinder head and oil temperatures exceed 68°F (+20°C).

Engine starting

1. Turn the propeller by hand (ignition switched off!)
2. Set the fuel selector to LEFT position
3. Set throttle lever to idle
4. Open the choke
5. Master switch to "ON"
6. Switch on ignition to "START" after starting to "BOTH"
7. Adjust engine RPM after starting
8. Close the choke
9. Warm up the engine

CAUTION

If the cylinder head and oil temperatures fall during parking. Start and warm up engine from time to time between flights. Do not open choke when starting a hot engine.

Parking and taxiing

Check wheel brakes for freezing when parked outside and temperature is below zero. Check wheels free rotation prior to taxiing (Grasp the propeller and pull the airplane). Heat the brakes with hot air (to melt snow or ice). Frozen materials should not be removed by forced towing.

After winter operation

- Clean the airplane thoroughly (hinges, especially the suspensions)
- Lubricate airplane per Lubricating Chart
- Check and adjust the control system



5. REPAIRS



5.1 Repair guidelines

5.1.1 Repair classification

Major repair, alteration or maintenance – Any repair, alteration or maintenance for which instructions to complete the task are excluded from the maintenance manual(s) supplied to the consumer are considered major.

Minor repair, alteration or maintenance – Any repair, alteration or maintenance for which instructions are provided for in the maintenance manual(s) supplied to the consumer of the product are considered minor.

Overhaul – Maintenance, inspection, repair or alterations that are only to be accomplished by the original manufacturer or a facility approved by the original manufacture of the product.

Repair Facility – A facility specifically authorized by the aircraft or component manufacturer to repair the product originally produced by that manufacturer.

5.1.2 Repair guidelines

NOTE

Repairs must be performed only by qualified persons – see 4.1.1 Qualification requirements.

Dents, cracks and loose rivets are the most frequent problems encountered during the operation of an all-metal airplane.

The following guidelines should be considered during repair:

1. The Strength in any cross-section of a repaired area/part should at a minimum be the same as the strength of the original undamaged area or part. The repaired area is not considered as a whole, but is considered as:
 - an original assembly unit
 - a stiffener or a patchIf the cross-section of a repaired area is (in all directions), at a minimum, the same as the one on the original part, or if a stiffener or a patch shape and design is similar, and the same materials are used, then there is no risk that the airframe will be weakened.
2. The load has to be transferred by a stiffener or a patch from one side of a repaired area to another.
In some cases, the load transmission should be carried out at another structural member and then back to an undamaged part of the original structure.
3. The length of overlapping between a reinforcement (stiffener or patch) and the undamaged part of the original structure should be enough to assure a good joint. The length of overlapping is very important to assure no load concentration.

5.2 Damage classification

Various types of damage may occur during aircraft operation. It is important to correctly classify damage according to its character, size and especially, which part of the airplane has been damaged.

The important parts are the engine, engine mount, propeller, wing spar, wing box in the fuselage, elevator, control system, and landing gear.

Any damage must be repaired only by person/repair station qualified in accordance with 4.1.1 Qualification requirements. The damaged parts may be replaced in their entity by new ones supplied by the aircraft manufacturer.

Any damage and its repair should be recorded in the Log Book.



5.3 Materials used

5.3.1 List of skin sheets

Duralumin sheets plated by aluminum are used for skins.

The following thickness are used:

0.016 in	0.4 mm
0.020 in	0.5 mm
0.024 in	0.6 mm

Material qualities are shown in the following table :

1	Czech Standard	Z 424253.61
		Al Cu Mg 1
2	Mechanical properties (Minimum)	Yield Point Rp 0.2
		260 MPa
		Tensile strength Rm
		400 MPa
		Ductility [%]
		15 (A10)
3	Chemical composition [%]	Al
		rest
		Fe max
		0.3
		Mn
		0.3 - 0.9
	Cu	
	3.8 - 4.9	
	Zn max	
	0.3	
	Mg	
	1.2 - 1.8	
	Si max	
	0.3	
4	Half-finished products	by Al plated Sheets Al thickness max. 10 mm <i>0.4 in</i>
5	Equivalent Standards	U.S.A. Germany Russia
		Alclad 2024 DIN 1745 D16AT

List of Skin Sheets:

Thickness	Airplane part
0.016 in (0.4 mm)	Elevator skin (except L.E.) Trim tab skin Rudder skin
0.020 in (0.5 mm)	Wing skin between rib 7 and 11 Flaps skin Ailerons skin Skin of upper rear part of a fuselage
0.024 in (0.6 mm)	Wing skin between rib 1 and 7 Elevator leading edge Skin of front, rear and bottom part of the fuselage



5.4 Skin repair

Type of maintenance: line.

Authorization to perform:

- Aircraft owner (only for ELSA)
- Sport pilot or higher
- Repairman (LS-M)
- Mechanic (A&P)
- Part 145 Repair station

1. To prevent small cracks (max. 0.2 in (5 mm)) from spreading, drill a hole of 0.06 in (1.5 mm), diameter at the end of the crack
2. Small holes (up to \varnothing 0.16 in (4 mm)) can be repaired by a "POP" rivets
3. More extensive skin damage is repaired by means of a patch. A flush or surface patch may be used, as shown on the following figure:

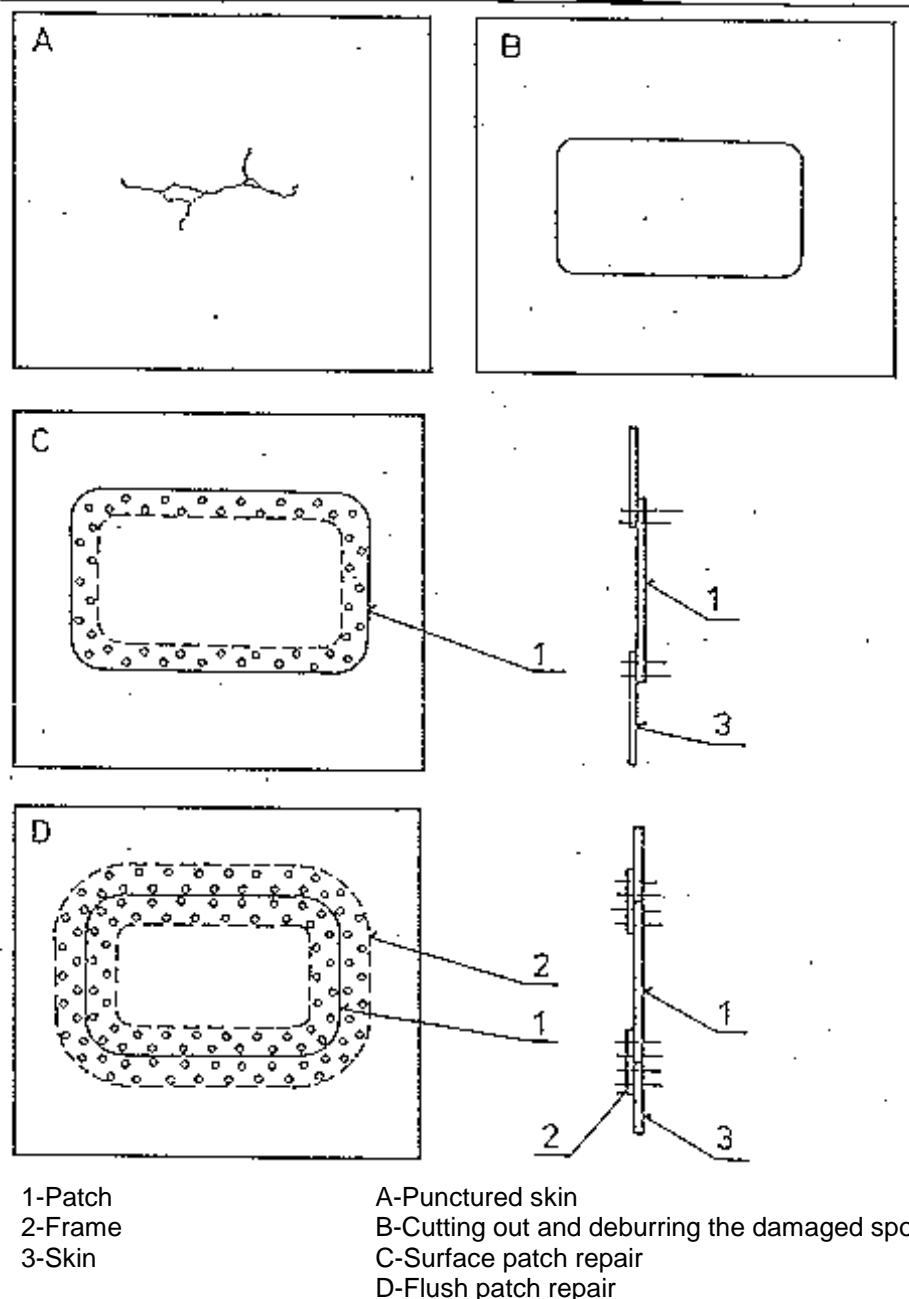



Use a sheet of the same thickness as the repaired skin for the patch and frame.
 A single row of rivets is used to rivet a small patch (patch area max. 7.75 sq in. 50 cm²). Use a double row for greater patches as shown on figure. Paint the internal side of the patch and frame before riveting and then paint the outside surface.

5.4.1 Riveting

"POP" rivets are used in most cases. Aircraft solid rivets are used only on wing spars, the wing box inside the fuselage and on some airplane parts with high loads. These parts must be repaired only by an authorized repair station.

When pop-rivets are to be removed, weaken the rivet head by drilling and then carefully drive out with a drift. Use a drill of the same size as the rivet. The rest of the rivet may be removed from the underside.

Pop-rivet joints are sealed. If necessary use a suitable knife to cut out the sealing compound and then clean the joint. Warm up shortly the sealed joint using hot air gun 356-392°F (180-200 °C) to make it easier to cut.

In the following table lists the pop-rivets and characteristics:

AVEX Pop-rivets supplied by AVDEL Company									
1. material : Al Mg 2.5									
2. Shank material: steel, zinc-chromate coating surface									
Rivet No.:	Diameter		Length		Hole diameter		Max. riveting thickness		Head
	[in]	[mm]	[in]	[mm]	[in]	[mm]	[in]	[mm]	
1691-0410	0.126	3.2	0.3110	7.9	0.130-0.138	3.3-3.5	0.031-	0.8-4.8	button
1691-0414	0.126	3.2	0.441	11.2	0.130-0.138	3.3-3.5	0.189	4-7.9	
1691-0512	0.157	4	0.374	9.5	0.161-0.170	4.1-4.3	0.157-	1.2-6.3	
1691-0516	0.157	4	0.050	12.7	0.161-0.170	4.1-4.3	0.311	4-9.6	
							0.047- 0.248 0.157- 0.378		
1604-0412	0.126	3.2	0.374	9.5	0.130-0.134	3.3-3.4	0.094- 0.248	2.4-6.3	counter-sunk

After drilling and deburring the holes apply Emfimastic PU50 sealing compound or equiv. on either part. Use a spatula to make a homogenous layer (0.004 in, 0.1mm).

Riveting should be done before the sealing compound hardenes (approximately half an hour).

For rivets spacing see surrounding skin; usually 0.8-1.6 in (20-40 mm) and keep a minimum distance of 0.3 in (8 mm) from the edge.



5.5 **Fiberglass parts repairs**

Type of maintenance: line.

Authorization to perform:

- Aircraft owner (only for ELSA)
- Sport pilot or higher

5.5.1 **Damage classification**

Any damage of parts from reinforces plastics with epoxy matrix leads to increased saturation of the matrix with humidity and subsequently to loss of properties. Therefore we recommend to carry out their repair as soon as possible after the damage has occurred.

Two kinds of parts are made from these materials in the airplane:

- structural, load-bearing parts (landing gear legs)
- design appearance, non load-bearing parts (fairings)

According to the damage size we can divide repairs into:

- small damage (surface defects, not affecting the stiffeners)
- medium damage (not more than 2/3 of stiffener thickness damaged)
- big damage

We recommend to carry out repairs by means of epoxy materials and glass stiffeners.

5.5.2 **General**

Epoxy mixtures are prepared in a given mass ratio by means of weighing (accuracy of scales 1g)

5.5.3 **Parts of external appearance**

5.5.3.1 **Small damage**

Repair of damage just by application of mastic and by varnish repair.

Preparatory grinding

For a good adhesion of repair layers it is necessary to carry out surface grinding at the utmost up to the depth of contact with the stiffener (do not damage). It is necessary to do surface grinding with overrun of 50 mm from the damage location smoothly to the top layer. It is suitable to do grinding with grain size of 160. Dry grinding equipment with suction from the grinding area is used. Al₂O₃ (fused corundum) can be used as grinding material.

Dust removing

It is made by wiping with clean and dry brush or by a vacuum cleaner.

Application of smoothing layer

After preparation of mixture (for material recommendation see tab below) and its eventual thickening to enhance the non curtaining capability (for vertical or lower areas) is performed its application onto the repair area by means of a spatula. For better distribution of deposited material on irregular surface it is possible to form it through the laid PE or PP transparent folie. After proper application the layer is without bubbles. Deposit thickness given by necessary thickness of surrounding layers (levelling) and ranges from 0.2 to 10 mm (0.0079 – 0.394 in) in one deposit.



Recommended materials for mixture preparation for application of levelling layer

manufacturer, name	type	míxing ration	dwelling	rate of setting	time of setting	temperature	fillers
HUNTSMAN, VANTICO, Araldite 2011 (AW106 + HV953U)	epoxy	A:B = 100:80	to be processed within 100min (for 0.1 kg mixture)	40%	24 hours (32hrs)	20 - 35°C (17 - 20°C)	thickening: Aerosil, microballs
				100%	48 hrs (72 hrs) (3 hrs)	20 - 35°C (17 - 20°C) (60°C)	

Grinding

Grinding or eventually sealing the surface is made after setting the mixture and possible tearing off the the used folie. It is suitable to start grinding with grain size up to 160 and finish with grain size of at least 400. It is carried out by dry grinding equipment with suction from the grinding area. Al2O3 (fused corundum) can be used as grinding material. Basic material of the part must not be diminished at grinding.

NOTE

Especially in case of C/K stiffener in the basic part, grinding through up to the stiffener must not occur (complication - see note about preparatory grinding at medium damage).

Finishing

See para 5.6 - Paint repairs.

5.5.3.2 Medium damage

Repair of damage by replacing the stiffener part, by mastic and varnish repair. At such repair it is necessary to distinguish type of used stiffener (especially for grinding):

- C/K (carbon/kevlar), rovings of fabric of black colour (C) take turns with yellowish (K)
- G (glass), rovings from milky white to transparent

Preparatory grinding

For good adhesion of repair layers it is necessary to do grinding up to the depth of damage. It is necessary to do surface grinding from the damage area with overrun at the least 25 mm (1 in) for every damaged stiffener layer smoothly up to the top layer and then about 50 mm (2 in) for finishing and mastic application. It is convenient to do grinding with grinding material having grain size of 160. It is carried out by dry grinding equipment with suction from grinding area. Al2O3 (fused corundum) can be used as grinding material.

NOTE

In case of C/K stiffener K rovings tend to rise up from the surface at grinding - it is difficult to grind them, we recommend to use diamond grinding tool and one-way grinding.

Dust removing

Dust is removed by wiping with a clean and dry brush or by a vacuum cleaner.

Stiffener preparation

For this kind of repairs we recommend the stiffener G (glass) with plain weave, 150g/m², with surface protection (drewwing) for epoxides.

Number of needed stiffener layers depends on depth of damage. It is possible to say that each layer of the mentioned fabric represents at proper saturation by matrix resin thickness of 0.5 mm (0.02 in).

Stiffener layers must be prepared (cut out) gradually from the smallest (the lowest) upto the bigger (upper), each with overrun of 20 mm (0.78 in).



Putting layers

After preparing lamination mixture (for recommendation of material see the Tab. on page 5-6), it is applied to the place of repair by means of rigid brush. The first stiffener is laid into the deposit and it is again saturated by brush. Another layer of stiffener is laid and saturated. When putting the last layer it is necessary to pay attention to a proper saturation and compression of stiffeners so that they cannot “come up” to the surface and subsequent useless damage at final grinding. For better saturation of the surface by resin and securing against curtaining it is possible to put PE or PP transparent foil across the surface. When applied properly, the layer is without bubbles. Repair thickness should exceed surrounding surface in this phase by about 0.5 to 1 mm (0.02 – 0.04 in) for finishing.

Grinding

Carry out grinding and eventually apply mastic on the surface after setting, eventually tearing off the foil (see small damage). It is suitable to begin grinding by abrasive with grain size of 160 and finish by grain size of at least 400. Dry grinding equipment is used with suction from the grinding area. Al₂O₃ can be used as grinding material. It is important not to diminish basic material of the part at grinding.

NOTE

Especially in case of C/K stiffener in the basic part there must not be any grinding through up to the stiffener (complication -see the note about preparatory grinding).

Finishing

See para 5.6 - Paint repairs.

5.5.3.3 Big damage

At such damage we recommend to change the part or to do this repair in a professional facility. Use instructions in chapter about medium damage as recommendation for used materials.

5.5.4 Structural parts

With these parts we do not recommend to do other repairs than small damage repairs. In case of the other damage we recommend to contact manufacturer.

CAUTION

When repairing, it is necessary to pay attention to timely repair (see the text about low of properties at humidity effect at the beginning of paragraph 5.5.1)!

Small damage

Repairs are made according to instructions with appearance parts.

CAUTION

When repairing, it is necessary to carefully pay attention not to damage the stiffeners!

Cracks, permanent deformations and breaks are the most relevant type of damage. Prior to undertaking the repair, clean the area to be repaired thoroughly, with soap and water. Remove any paint by wet or dry sanding. Superficial scars, scratches, surface abrasions, or erosion can generally be repaired by applying one or more coats of epoxy resin. The number of coats required (2 generally) depends upon the type of resin and severity of damage. The layers should have an overlap of 1.5-2 in (30-50 mm). After the resin has cured, sand off any excess and prepare the area for priming and painting.

If the area to be repaired is large, use a temporary block or mold coated with PVC or PE foil to support the repaired area.

5-8	Document No.: SSM2008MAIPUS	Date of Issue: March 01, 2009	Revision: -
------------	--	--	-----------------------



5.6 Paint repairs

Type of maintenance: line.

Authorization to perform:

- Aircraft owner (only for ELSA)
- Sport pilot or higher

5.6.1 Safety rules

When working with paints, thinners and solvents follow the following safety rules:

- it is necessary to follow safety rules for working with flammable and volatile substances
- working area must be properly aerated
- it is prohibited to smoke and anyway handle with free fire in a working area
- use protective working means such as goggles, gloves, respirator, etc.

5.6.2 Recommendation for paint repairs

CAUTION

By applying paints weight of airplane is increased and centre of gravity position is changed. Increase in weight depends on type of coat and its thickness.

5.6.2.1 Washing and degreasing

It is possible to use both organic solvents and solvents based on water.

(a) **Organic solvents** - acetone, metyetylketone (MEK), benzine, toluene, BASF Glasurit 360-4

- Applied by spraying on washed surfaces (e.g. mechanical sprayer, jet ejector) or by wiping with wet (by pouring, not by dipping because it would contaminate the whole volume of solvent) textile wad. After applying it, the agent is wiped off by clean absorbing material before solvent evaporation.
- **Advantages:** fast and reliable evaporation even from the corners and borders without additional warming.
- **Disadvantages:** it must be used without other dilution (expensive); not ecological (danger of water contamination); detrimental to health (must be carried out in an aerated area with personal protective means); waste (including dripping from the area) must be eliminated in the incinerating plants.
- **Use:** for Al-alloys surfaces, epoxide fibreglass

CAUTION

These agents must not be used for degreasing parts from plastics (PC - Lexan, PMMA - Plexiglas)

(b) **Water-based** agents - emulgation substances, wetting agents

- Applied also by spraying onto washed surfaces or by wiping with wet (by pouring and dipping) textile wad. After applying it, let it act for some time (see manufacturers recommendation) and then it is rinsed with clear water (by means of sponge dipped in ample amount of water or water jet).
- **Advantages:** (different according to the type of product: it is possible to highly dilute with water (cheap); ecological - waste (including dripping from the surface - due to ample amount of water it is necessary to contain it) can be generally eliminated after its additional dilution with water in public sewerage; the least detrimental to health.
- **Disadvantages:** slow and unreliable evaporating from corners and borders, additional warming (drying) mostly required - imperfect elimination of water results in wrong adhesion of paint coats; imperfect degreasing of fibreglass parts (not possible to use)



- **Use:** for Al-alloys surfaces and plastics

5.6.2.2 Bonding rivet heads, big irregularities and material transitions

CAUTION
In case that airplane surface remains without top coat, carry out just rivet head bonding.

After perfect degreasing carry out bonding of rivet heads, big irregularities and transitions of fibreglass parts with Al-sheet.

Epoxide and polyester bonding agents for car bodies are suitable; moreover for transitions between two types of material with increased elasticity. Recommended bonding agents are shown in the following tables.

Polyester bonding agents are applied with plastic spatula after being mixed with initiator. Grinding with grinding paper with grain size of 240 is made to smooth surface after drying. Remove dust after grinding and clean with degreasing agent.

Epoxide bonding agent is applied from the special jet with static mixer by means of extruding pistol. Excessive material is wiped off with spatula to final appearance before setting (slight recess is not a defect) - **do not grind!**

Recommended bonding agents:

surface	manufacturer, name	type	other components	drying (grindable) [min] / 20°C
Al-alloys	BASF Glasurit 839-10 (base)	polyester	BASF Glasurit 948-36 (initiator)	30
transitions epoxide- fibreglass + Al- alloys	BASF Glasurit 839-45 (base)	polyester	BASF Glasurit 948-36 (initiator)	150
Rivet heads	3M DP-190 (base+ hardener)	epoxide (elastic)		360

5.6.2.3 Application of primer (paint)

In order to reach a uniform resistance to corrosion and smooth surface, we recommend to carry out application by means of spraying (air standard gun with the upper vessel, air HVLP gun, airless electric gun). The adjusting of the used gun (given by manufacturer) differs according to the type - air pressure, jet diameter. Primer should be applied in several sprayings (total thickness is not reached at a blow) with defined maximum dwell and total drying time till further treatment or handling.

Primer serves especially for anchoring (adhesion to the substrate) the top coats and can serve also for eliminating irregularities of the surface (function of filler, for grinding).

For surfaces from Al-alloys we recommend to use the etch-primers for light metals based on alkyd or materials based on epoxides or polyurethans (2-component paints); specific recommendations according to the table on the next page.

Recommended primers

Surface	Manufacturer, name	Type	Further components	Surface mass [g/μm/m ²]	Recommended thickness [μm]	Drying (between spraying/total) /20°C
Al-alloys	BASF Glasurit 801-1871 (base)	epoxide	BASF Glasurit 965-32/2 (hardener) Glasurit 965-50 (thinner)	1.62	25 (at 50 it can be also used as filler)	15min / 12hour
epoxy- fibreglass						
PC (Lexan), PMMA (Plexiglas)						

5.6.2.4 Bonding

After total drying of basic coat we recommend to carry out total bonding of irregularities including repairs of bonding. Recommended binders are shown in the table - Recommended bonding agents. After drying perform grinding with emery paper with grain size of 240 until the surface is smooth. After grinding clean dust and wipe off with grease remover and perform repairing paint coat by primer (1//3of coat thickness)

5.6.2.5 Application of top coat

In order to reach smooth surface we recommend again to carry out the paint coat by spraying (see para 5.6.2.3).

Top coat serves especially for creating the coat resistant to weather and external effects for aesthetic rendering of the unit. Considering the higher loading by external effects we recommend to use top materials, exclusively two-component ones, on the acrylic-polyurethan or polyurethan basis, always with guaranteed adhesiveness to the used base coat (according to manufacturer). It is possible to use some of the coat systems for car repairs. In our recommendation (see the tab. 3) there are two types of colours: single coat (colour shade and protection in one), double coat (one-component colour shade is formed by the substrate and protection is ensured by two-component transparent top coat). By single coat paint coat it is possible to reach the wide spectrum of colours, but it is difficult to do metallic paint coats (we do not recommend them).

Recommended colours

type of colour	manufacturer name	type	other items	surface weight [g/μm/m ²]	recommended thickness [μm]	drying time (between spray-coats / total) /20°C
single coat	BASF Glasurit R-18/ shade (base)	acrylic- polyure than	BASF Glasurit 922-18 (standard hardener) Glasurit 352-91 (standard thinner)	1.0-1.6 (by shade)	20-40	15 min / 16 hrs
Double- coat	base colour coat: BASF Glasurit R-55/ shade (base)	acrylic- polyure tan	BASF Glasurit 352-216 (thinner, long)	1.2-1.4 (by shade)	15-20	10 min / 20 min



type of colour	manufacturer name	type	other items	surface weight [g/μm/m2]	recommended thickness [μm]	drying time (between spray-coats / total) /20°C
	top coat, bright:: BASF Glasurit 923-155 (base)	acrylic-polyure than	BASF Glasurit 929-73 (standard hardener) Glasurit 352-91 (standard thinner)	0.92	30-40	5 min / 5 hrs

5.6.3 Small damage

5.6.3.1 General

Small damage is a deterioration of corrosion resistance. At repair the situation is made more difficult by the fact that the substrate for repair coats is not a compact surface of basic material but mostly all coats of surface protection (after grinding), of which not all are suitable for (in ageing stage) for good adhesion of paint coats. Therefore we recommend to carry out such repairs by a verified system.

Before repairing it is necessary to differentiate the type of the existing top coat, single coat and two-coat (with the top coat). For repair it is necessary to follow the used type of colour.

It is suitable to choose the delimited area (e.g. connection of sheets, wing edge) for the scope of the place which is being repaired transition is then better blended. In the case that it is not possible to choose the area in this way, it is necessary to take into consideration the higher difficulty of the procedure as for the uniformity of shade and elaboration of coat transition.

5.6.3.2 Grinding

For good adhesion of the repair coats it is necessary to carry out grinding of the old paint coat at least up to such depth as the depth of damage. With two-coat type of the top coat it is necessary to add at least 50 mm (2 in) for the run-out of the top coat. Grinding can be started with abrasive having grain size of max. 160 and to finish with grain size of 400. It is made by the grinding equipment with the suction from the area of grinding or by manual grinding under water.

CAUTION

Anodized coat must not be destroyed by grinding on the Al-alloy sheet.

5.6.3.3 Degreasing

It is carried out in the same way as in the case of the total spray coat - see para 5.6.2.1



5.6.3.4 Application of primer

For reaching the satisfactory equal adhesion we recommend to carry out a spray coat of the place to be repaired by adhesive interlayer (see the tab. below).

Adhesive interlayer

surface	manufacturer, name	type	surface weight [g/μm/m ²]	recommended thickness [μm]	drying (total) /20°C
Al-alloys	BASF Glasurit 934-0	single-component	0.8	5-10	max. 15 min
Epoxy fibreglass					
Old paint coats					

Subsequently the primer is applied according to the table **Recommended primers**. Paint coat thickness is given by necessary thickness of surrounding coats (levelling).

CAUTION

In case that the primer was not removed by the previous step, it is not necessary to apply the primer again. The original ground primer with adhesive intercoat is enough.

Actual application of primer will be carried out in the same way as for the total spray-coat (see 5.6.2.3).

5.6.3.5 Application of top coat

CAUTION

For repairing it is necessary to choose the identical type (single coat, double coat) of the repair colour as on the original surface.

Application of the top coat will be carried out by spraying as for the total spray coat (see 5.6.2.3) with the exception of used thinners and hardeners. Due to the need of smooth transition to the basic surface and it is necessary to use so called "spraying into the surface" using longer time of drying initiations for a good result of work. The recommended material is shown in the table below.

Recommended colours

type of color	manufacturer, name	type	other components	surface weight [g/μm/m ²]	recommended thickness [μm]	drying (between spray coats/ total) /20°C
single coat	BASF Glasurit R-18/ shade (base)	acrylic-polyurethan	BASF Glasurit 922-18 (standard hardener) Glasurit 352-319 (extra long thinner)	1.0-1.6 (according to shade)	20-40	15 min / 19 hrs
double coat	basic colour code: BASF Glasurit R-55/ shade (base)	acrylic-polyurethan	BASF Glasurit 352-216 (long thinner)	1.2-1.4 (according to shade)	15-20	10 min / 20 min



type of color	manufacturer, name	type	other components	surface weight [g/ μm^2]	recommended thickness [μm]	drying (between spray coats/ total) /20°C
	Glossy top coat : BASF Glasurit 923-155 (base)	acrylic-polyurethan	BASF Glasurit 929-73 (standard hardener) Glasurit 352-400 (extra long thinner)	0.92	30-40	5 min / 6 hrs

5.7 Airplane assembly and leveling after a repair

Type of maintenance for the pitot static instruments: heavy.

Authorization to perform:

- Repairman (LS-M) or Mechanic (A&P) – both with the minimum level of certification to perform heavy maintenance of SLSA in the U.S.
- FAA approved Part 145 Repair station

When major damage is repaired the following should be performed:

- Technical inspection by qualified person with attention to wiring, tightening and securing of appropriate joints, clearances in the control systems and control surfaces movement.
- Leveling
- Weight; Balance changes
- Control surfaces deflections measurement
- Engine test run
- Test flight
- Remedy of the defect



5.8 First flight after a repair

CAUTION

Only qualified pilots may perform the test flight.

The following information is intended for the aircraft owner.

A test flight is mandatory in the following cases:

After repair or replacement of fixed surfaces - wing, fin, stabilizer, or control surfaces i.e. elevator, aileron or flap. The flight characteristics and stability can be affected when any of these parts are replaced or adjusted. Therefore a test flight should be performed to check the airplane flight characteristics, control surfaces setting, maneuverability, stability and stall characteristics. These characteristics are to be checked during taxiing, takeoff, climbing, cruise, descent, approach and landing. In other words all flight modes!

Use the Flight Test Record (see Appendices of this Procedures) to record data obtained during a test flight.

Test flight flying time

A test flight, if carried out in accordance with SportStar MAX Test Flight Record provided in appendices of this Manual, would take approximately one hour.

Aircraft inspection before a Test flight

Prior to the test flight the aircraft should be thoroughly inspected, weighed, faults corrected by qualified personell. Then and only then the airplane be prepared for the flight.

Test crew

Only qualified persons (test pilots) are permitted to perform a test flight.

Any failures found during test flight should be removed prior to next flight.

5.9 Spare parts order

Use the "Spare Parts Order" form to order a replacement for a damaged or worn-out part. Do not hesitate to contact the airplane manufacturer (phone or fax) to request a required part.

On the Spare Part Order form additional information is necessary for systematic monitoring and analysis of our planes reliability.

5.10 Recommended reading

Many useful information you can find in the document :

Acceptable Methods, Techniques, and Practices – Aircraft Inspections, Repair & Alternations
AC 43.13-1B, AC 43.13-2A



Intentionally left blank



6. APPENDICES



6.1 List of Appendices

1. Description of actual airplane
2. Weight and Balance Record
3. Control Surfaces Deflection Record
4. Leveling Record
5. SportStar MAX Test Flight Record
6. Spare Parts Order
7. Airplane Failure Card
8. Airplane Placards
9. Airplane Wiring diagrams
10. Service Instruction SI-912-016 R2, Selection of Suitable Operating Fluids for Rotax engine Type 912 and 914 Series
11. Sonnenschein A500 batteries operating instructions (used type - A512/16.0 G5)
12. Cleaning, polishing and tips for repairing little crazing in a plexiglas glazing – Weiss plexiglas
13. Color scheme of actual airplane
14. EAA Quick Guides