

# ROTAX 912 ULS - DCDI

ROTAX 912 ULS - 100 HP

Info Pak

Part No. 999-680

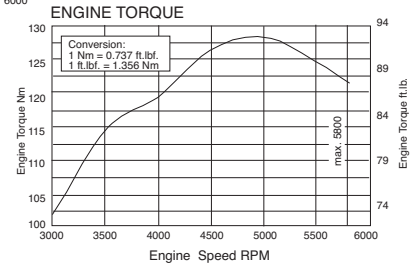
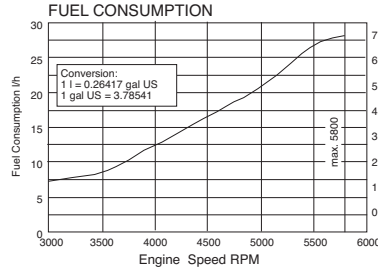
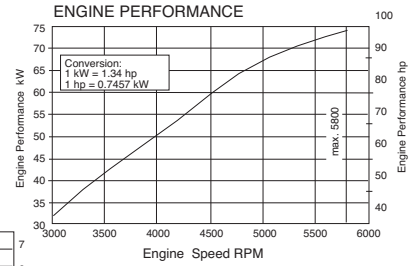
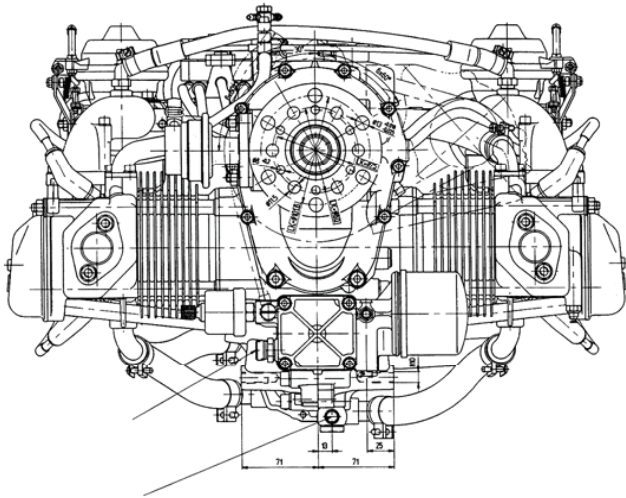
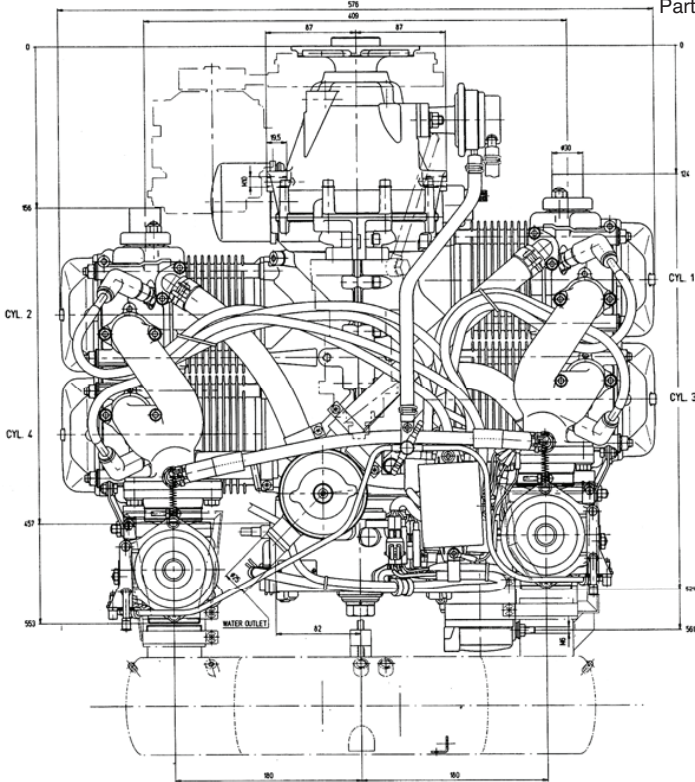

## ROTAX 912 ULS - DCDI

4-Cylinder, 4-Stroke liquid/air cooled engine with opposed cylinders, dry sump forced lubrication with separate 3 liter (.8 gal US) oil tank, automatic adjustment by hydraulic valve tappet, 2 CD carburetors, mechanical fuel pump, electronic dual ignition, electric starter, integrated reduction gear  $i = 2.43$ .

VERSION	PERFORMANCE			TORQUE			MAX RPM
912 ULS	kW	hp	1/min.	Nm	ft. lb.	1/min.	1/min.
max. 5 min.	69.0	95	5500	128	94	5100	5800
	73.5*	100*	5800*	* w/ROTAX airbox and exhaust system			
BORE	STROKE	DISPLACEMENT		COMPRESSION RATIO			
84 mm 3.31 in.	61 mm 2.4 in.	1352 cm <sup>3</sup>	82.6 cu. in.	10.5:1			
FUEL		OIL		COOLING LIQUID			
min. MON 85 RON 95* min AKI 91*		API SF or SG		50% BASF Glysanthin Anticorrosion 50% Water			
* leaded or unleaded or AVGAS 100 LL							
IGNITION UNIT		IGNITION TIMING		SPARKPLUG			
DUCATI double CDI		4° up to 1000 RPM above 26°		ROTAX Part No. 297-940			
GENERATOR PERFORMANCE		RPM		VOLTAGE			
250 W DC		5500		13.5 V			
STANDARD				WEIGHT			
Engine with gearbox $i = 2.43$				kg		lb	
				56.6		124.8	
OPTIONS		WEIGHT		kg		lb	
Oil radiator Part No. 886-029						0.5 1.1	
Radiator Part No. 995-697				1.0		2.2	
Slipping Clutch				1.7		3.7	
Airbox				1.3		2.8	
Air Cleaner				0.15		0.3	
Exhaust System				4.0		8.8	
Air Guide Hood				0.8		1.8	
Vacuum Pump				0.8		1.8	
Hydraulic Propeller Governor				2.7		5.9	
External Alternator 40A/12 V DC				3.0		6.6	
Engine Truss Assembly				2.0		4.4	
Rectifier Regulator				0.1		0.2	
Instrument FLYdat				0.5		1.1	
Recall Instrument RDAT				1.0		2.2	
Fuel pump with installed fuel lines				0.2		0.4	

ROTAX 912 Operational Values with Limits	
<b>RPMs</b>	Take off speed - 5,800 rpm (5 min. max) Max. Continuous speed - 5,500 Idle Speed - near 1,400 rpm
<b>CHT</b>	Max. Temp. - 150°C (300°F)
<b>EGT</b>	Normal 1,472° F Max. - 1,652° F 4-6" From Exhaust valve - 2" From Engine
<b>Coolant Pressure</b>	12-17 PSI
<b>Oil Pressure</b>	Normal-58 PSI Max. - 72 PSI Min. - 22 PSI @ 2,800 rpm Cold Start Max. - 102 PSI
<b>Oil Temperature</b>	Most favorable operating temp: 190°-230°F (90-110°C)
<b>Fuel Pressure</b>	5.8 PSI

**TBO ON NEW 912 ULS ROTAX ENGINES IS 1500 hrs.**

You can also upgrade the following existing serial numbers 4,427,533 and higher. Please call our engine shop for pricing.

independent SERVICE CENTRE  
**ROTAX**  
AIRCRAFT ENGINES

**LEADING EDGE AIR FOILS, LLC 1-800-532-3462 info@leadingedgeairfoils.com**  
**www.leadingedgeairfoils.com store.leadingedgeairfoils.com**